



AGENDA

Study Session, Regular Meeting and Closed Session of the Bloomfield Hills Schools Board of Education

Doyle Center for Professional Development
7273 Wing Lake Road | Bloomfield Hills, MI 48301

www.bloomfield.org/livestream

February 24, 2025
6:00 PM

1. Call to Order

- A. Call to Order
- B. Attendance

2. Study Session

- A. Board Committee Reports
- B. Organizational Planning Discussion

3. Reconvene

- A. Call to Order Regular Meeting @ 7:30 p.m.
- B. Attendance
- C. Pledge of Allegiance

4. Special Recognition

- A. Celebrating Success: Scholastic Art & Writing Award Recipients
BHHS Art Teachers: Tessa Basirico, Matthew Beauchamp, and Peg Pasternak

Students being recognized:

Sierra Anthony, Mark Asmar, Athena Atchoo, Sage Booth, Evie Dale, Yunjia Gan, Jordyn Goldstein, Anna Kohl, Brody Oleshansky, Dylan Psenka, Jared She, Ashley Shulkin, Andrew Siu, and Mia Wrath

5. Superintendent's Report

Rick West, Superintendent

6. Board President's Report

Meagan Hill, Board President

7. Board Intern and Student Advisory Committee Report

Ayah Maskoun and Adeline Sherman, Board Interns

8. Public Comment

A. Public Comment

To submit public comment during a meeting of the Bloomfield Hills Schools Board of Education, please complete a comment card and present it to the administrative professional recording minutes prior to the agenda item.

9. Consent Agenda

A. Consent Agenda

Carolyn Noble, Board Secretary

I move that the Board of Education approve the recommendations detailed in the Consent Agenda, as presented.

B. Request to Approve Minutes from the Organizational and Regular Meeting of January 27, 2025

Carolyn Noble, Secretary

I move the Board of Education to approve the minutes from the organizational and regular meeting of January 27, 2025, as presented.

C. Request to Approve Disbursement Reports

Kandice Moynihan, Assistant Superintendent of Business Services

I move the Board of Education to approve the disbursement reports, as presented.

D. Request to Approve Monthly Financial Report

Kandice Moynihan, Assistant Superintendent of Business Services

I move the Board of Education to approve the monthly financial report, as presented.

E. Request to Approve Purchase of Replacement Vehicles for Maintenance & Operations

Jacob McDermott, Director of Maintenance and Operations

I move the Board of Education to approve the purchase of one (1) 2025 GMC Sierra 3500HD, and (1) 2024 GMC Savana 3500 for Maintenance and Operations in the total amount of \$103,508 to Todd Wenzel Buick GMC to be paid from the General Fund, as presented.

F. Request to Approve Personnel Actions

Keith McDonald, Deputy Superintendent

I move the Board of Education to approve the personnel actions, as presented.

10. Special Reports

A. Bond Quarterly Report

Allen Dresselhouse and David Goldman, Plante Moran Realpoint

11. Board Business

- A. Request to Award Bid #1052 - Asbestos Abatement (Conant, Eastover, Lone Pine and Way Elementary Schools)

Jacob McDermott, Director of Maintenance and Operations

I move the Board of Education to award RFP #1052 to Environmental Maintenance Engineers, Inc. for asbestos abatement Conant, Eastover, Lone Pine and Way Elementary Schools in the amount of \$90,000, to be paid from the Bond Fund, as presented.

- B. Request to Award Bid #1050 - Roof Work (Bloomfield Hills High School, Conant and Eastover Elementary Schools)

Jacob McDermott, Director of Maintenance and Operations

I move the Board of Education to award RFP #1050 to Tri-Star Roofing to replace sections of the roofs at Bloomfield Hills High School, Conant Elementary School, and Eastover Elementary School in the amount of \$1,058,970, to be paid from the Sinking Fund, as presented.

- C. Request to Approve Purchase of Wing Lake Developmental Center Playground Upgrades

Jacob McDermott, Director of Maintenance and Operations

I move the Board of Education to approve the purchase of new playground equipment and additional soft surface for the Wing Lake Development Center from Snider Recreation, utilizing the OMNIA Cooperative Program, in the amount of \$212,790 and to be paid from the Center Program Fund, as presented.

- D. Selection of Candidate for Michigan School Boards Association Board of Directors

Board of Education

I move the Board of Education of Bloomfield Hills Schools to designate (name) as the Region 8 candidate for the MASB Board of Directors, and to direct the Office of the Superintendent to cast the vote accordingly.

12. Closed Session

- A. Closed Session per MCL 15.268 Sections 8(k) and (h)

Rick West Superintendent

I move the Board of Education convene a closed session in accordance with MCL 15.268 Section 8(k) to consider security planning to address existing threats or prevent potential threats to the safety of students and staff, and Section 8(h) to consider material exempt from discussion or disclosure by state or federal statute.

Two-thirds roll call vote required.

Under Section 8(h) of the OMA, a closed session of the Board is permitted, upon rollcall vote of 2/3 of the serving members of the Board, "to consider material exempt from discussion or disclosure by state or federal statute." The state statute involved here is FOIA, Section 13(1)(g) of which exempts from disclosure "Information or records subject to the attorney-client privilege." Thus written opinions of legal counsel, which are subject to the attorney-client privilege, may be considered in a closed session.

13. Adjournment

Public Comment is a time for individuals to share their thoughts with the Board; however, it is not a time for dialogue with the Board. Those who wish to speak at Public Comment are asked to complete a Public Comment Request Card. In the interest of fairness, the Board will announce a speaker time limit

based on the number of cards submitted and available time.

If you have a disability requiring a reader, amplifier, qualified sign language interpreter, or any other form of auxiliary aid or service, please call the Office of the Superintendent at 248-341-5406 at least one week prior to the meeting or as soon as possible.

Board Minutes are Located at:

<http://www.bloomfield.org/board-of-education>

Bloomfield Hills School Board of Education

7273 Wing Lake Road

Bloomfield Hills, MI 48301

248-341-5406



Bloomfield Hills Board of Education

Memo

To: Superintendent and Board of Education
From: BHHS Art Teachers: Tessa Basirico, Matthew Beauchamp, and Peg Pasternak
Date: February 24, 2025
Re: Celebrating Success: Scholastic Art & Writing Award Recipients

Recommended Motion:

Students being recognized:

Sierra Anthony, Mark Asmar, Athena Atchoo, Sage Booth, Evie Dale, Yunjia Gan, Jordyn Goldstein, Anna Kohl, Brody Oleshansky, Dylan Psenka, Jared She, Ashley Shulkin, Andrew Siu, and Mia Wrath

Background Information:

Each year, students across the country submit art and writing pieces to the Scholastic Art and Writing Awards Program, the nation's longest running, largest and most prestigious program for creative teens. Amongst the thousands of entries received each year, approximately 20% make it into the exhibit and earn either a gold key, silver key, or honorable mention award. Gold key recipients will advance to the national awards this spring. Congratulations to the following student artists:

- Sierra Anthony (BHHS: grade 12):
 - Gold Key Individual Category in Art: Innerworkings
 - Silver Key Individual Category in Art: Splice
- Mark Asmar (BHHS: grade 12):
 - Silver Key Individual Category in Art: Cool Headed
- Athena Atchoo (BHHS: grade 12):
 - Gold Key Individual Category in Art: Nana Vicky

- Sage Booth (BHHS: grade 12):
 - Gold Key Art Portfolio: The Roots, The Bloom: Consequences
 - Silver Key Individual Category in Art:
 - The Birth Myth
 - The Wild Chase
- Evie Dale (NHMS: grade 8):
 - Silver Key Individual Category in Art: Anxiety
- Yunjia Gan (IA Okma: grade 11):
 - Gold Key Individual Category in Art: Ephemeralty
- Jordyn Goldstein (BHHS: grade 10):
 - Silver Key Individual Category in Art:Skull
- Anna Kohl (BHHS: grade 12):
 - Silver Key Individual Category in Art:Lobster Cutlery
- Brody Oleshansky (BHHS: grade 12)
 - Silver Key Art Portfolio: Discovering Human Faces Through an Unconventional, Cubistic Lens
- Dylan Psenka (BHHS: grade 12)
 - Gold Key Art Portfolio and Best of Show Portfolio: A World Worth Saving
 - American Vision Award: Deep Sea Sanctuary
 - Gold Key Individual Category in Art:
 - Crochet Motif Blanket
 - Rewired Roots
 - Ecosystem Malfunction
 - Deep Sea Sanctuary
 - Silver Key Individual Category in Art: Glow of the Deep
- Jared She (BHHS: grade 10):
 - Silver Key Individual Category in Art:Silent Reverence
- Ashley Shulkin (BHHS: grade 10):
 - Silver Key Individual Category in Art:
 - In the Shadow of Regret
 - Lost in the Lure
- Andrew Siu (BHHS: grade 12):
 - Gold Key Individual Category in Art:
 - I Miss You
 - The Shame in [Fe]eeling
 - Silver Key Individual Category in Art:
 - Deadline

- Mia Wraith (BHHS: grade 12):
 - Silver Key Art Portfolio: Waves
 - Silver Key Individual Category in Art:
 - Fungi
 - Metamorphosis

ATTACHMENTS:

File Name

Description

No Attachments Available



Bloomfield Hills Board of Education

Memo

To: Superintendent and Board of Education
From: Carolyn Noble, Secretary
Date: February 24, 2025
Re: Request to Approve Minutes from the Organizational and Regular Meeting of January 27, 2025

Recommended Motion:

I move the Board of Education to approve the minutes from the organizational and regular meeting of January 27, 2025, as presented.

Background Information:

ATTACHMENTS:

File Name	Description
📎 January_27__2025_Organizational_and_Regular_Board_Meeting_Minutes.pdf	Minutes from the Organizational and Regular Meeting of January 27, 2025



**Doyle Center for Professional Development
7273 Wing Lake Road, Bloomfield Hills, Michigan 48301**

**MINUTES FROM THE ORGANIZATIONAL AND REGULAR MEETING
OF THE BLOOMFIELD HILLS SCHOOLS BOARD OF EDUCATION**

**January 27, 2025
6:00 p.m.**

**[Recorded Meeting Link](#)
[January 27, 2025 Agenda Package](#)**

I. CALL TO ORDER

A. Call to Order

Meagan Hill, President, called the meeting to order at 6:00 p.m.

B. Attendance

Paul Kolin, Treasurer, took attendance, and the board members constituting a quorum were:

Meagan Hill, Board President

Tareq Falah, Vice President

Paul Kolin, Treasurer

Jason Abel, Trustee

Lindsay Baker, Trustee

Michelle Southward, Trustee

Members of the district's administration and agenda item presenters, were in attendance as follows:

Samer Alsayed Suliman, Director of Information Technology

Todd Bidlack, Assistant Superintendent of Learning Services

Rebecca Catherincchia, Executive Administrator

Dan Hartley, Principal of Bloomfield Hills High School

Sarah Fairman, Executive Director of Secondary Education

Karen Huyghe, Director of Communications

Kevin Massey, Senior Vice President at Plante Moran Realpoint

David Shulkin, Director of Instructional Technology

Kevin Sutton, Attorney at Miller Johnson, PLC

Rick West, Superintendent

C. Pledge of Allegiance

II. ORGANIZATION OF THE BOARD

A. Oath of Office Ceremony

Martin Brook, Bloomfield Township Clerk, ceremoniously administered the oath of office to newly elected trustees, Jason and Abel, and to re-elected trustee, Michelle Southward. Their terms are effective January 1, 2025 through December 31, 2028.

B. Board of Education Officers

Tareq Falah nominated Meagan Hill to the office of President through December 31, 2025. Meagan Hill accepted the nomination which passed in voting.

Paul Kolin nominated Tareq Falah to the office of Vice President through December 31, 2025. Tareq Falah accepted the nomination, which passed in voting.

Michelle Southward nominated Carolyn Noble to the office of Secretary through December 31, 2025. Carolyn Noble was not present, but had previously expressed interest in continuing service in this capacity, and as such the nomination passed in voting.

Michelle Southward nominated Paul Kolin to the office of Treasurer through December 31, 2025. Paul Kolin accepted the nomination, which passed in voting.

Ayes: Abel, Baker, Falah, Hill, Kolin, Southward

Nayes:

Motion Passed: 6/0

C. Board of Education Committee, Liaison, and Representative Appointments

After discussion at the board table, the agenda item was amended and divided into two parts, as follows.

a. Board Committees

President Hill appointed the trustees to serve on the following committees through December 31, 2025:

- Curriculum and Instruction: Falah (Chair), Baker, Southward
- Finance and Operations: Kolin (Chair), Baker, Noble
- Strategic Planning: Abel (Chair), Noble, Southward

As President, Meagan will serve as substitute should a trustee not be able to attend a committee meeting.

b. Liaison and Representative Appointments

After some deliberation at the board table about committing to the stakeholder groups, the topic was deferred to the February 24, 2025 study session.

D. Board of Education Committee Dates

President Hill asked that the Committee Chair work with the administration regarding the proposed calendar of committee meeting dates.

E. Board of Education Meeting Dates

It was moved by Paul Kolin and supported by Tareq Falah the Board of Education to approve the schedule of regular meetings beginning July 1, 2025 through June 30, 2026, as presented.

Ayes: Abel, Baker, Falah, Hill, Kolin, Southward

Nayes:

Motion Passed: 6/0

III. ADMINISTRATIVE APPOINTMENTS

A. Administrative Appointment of Robert Phelps, Ed.D, Director of Curriculum

It was moved by Michelle Southward and supported by Tareq Falah that Dr. Robert Phelps be appointed as the Director of Curriculum with an effective date of January 27, 2025.

Ayes: Trustees Abel, Baker, Falah, Hill, Kolin, Southward

Nayes:

Motion Passed: 6/0

IV. SPECIAL RECOGNITION

A. Celebrating Success: Tri-County High School Art Exhibition Awards

Dan Hartley, Bloomfield Hills High School Principal, recognized Matt Beauchamp, Art Educator and Visual Arts Department Chair for receiving the Teacher Award at the Tri-County High School Art Exhibition. Also recognized were the 18 students whose artwork was accepted to the exhibition. Congratulations to Roman Bahri, Sage Booth, Renee Charnesky, Jordyn Goldstein, Leah Goldstein, Ellamarie Gordhamer, Magnus Jurtz, Anna Kohl, Birdie Parker, Dylan Psenka, Andrew Siu, and Kina Wack for being featured out of the 120 works the jurors selected to be included in the final exhibit.

B. National School Board Recognition Month: Board Member Appreciation

On behalf of the organization, Rick West presented board members with mementos of appreciation for their service in recognition of National School Board Month. A proclamation prepared by Governor Gretchen Whitmer was read aloud dedicating January 2025 as School Board Recognition Month.

On behalf of the PTOC, Paulina Hakopian and Alex Lenkowski offered remarks of gratitude for their board service, and presented mementos of thanks.

V. SUPERINTENDENT'S REPORT

Superintendent West presented highlights of recent activities taking place across the District, as well as upcoming events.

VI. BOARD PRESIDENT’S REPORT

President Hill discussed the onboarding of new board members, organizational meeting preparations, and professional development opportunities afforded to the trustees.

VII. BOARD INTERN AND STUDENT ADVISORY COMMITTEE REPORT

Members of the Board Intern Program reported on their work to bridge any gaps between the middle school and high school athletic teams, co-curriculars, clubs, and other offerings to encourage further interest, and improve the student experience. The students have also begun engaging with Bowers Academy to expand their reach and to foster inclusivity. The report ended with a points of pride summary curated by the group.

VIII. PUBLIC COMMENT

No requests for public comment were received.

IX. CONSENT AGENDA

A. Consent Agenda

It was moved by Paul Kolin and supported by Tareq Falah to approve the recommendations detailed in the Consent Agenda, as presented and recommended by the Administration.

- Request to Approve Minutes from the Study Session, Closed Session and Regular Meeting of December 16, 2024
- Request to Approve Minutes from the Special Meeting of January 2, 2025
- Request to Approve Disbursement Reports
- Request to Approve the Monthly Financial Report
- Request to Approve Personnel Actions

Ayes: Trustees Abel, Baker, Falah, Hill, Kolin, Southward

Nayes:

Motion Passed: 6/0

X. BOARD BUSINESS

A. Request to Approve Bid Pack 12 - Lone Pine Elementary Front Entrance Site Work

It was moved by Tareq Falah and supported by Michelle Southward to approve Bid Package 12 - Lone Pine Elementary Front Entrance Site Work in the amount of \$365,310, inclusive of 10% contingency, to be paid from the Bond Fund, as presented.

Ayes: Abel, Baker, Falah, Hill, Kolin, Southward

Nayes:

Motion Passed: 6/0

B. Request to Approve Bid Pack T8 - Technology Systems

It was moved by Jason Abel and supported by Michelle Southward to approve Bid Package T8 - Technology Systems in the amount of \$2,017,300.85, inclusive of 10% contingency, to be paid for from the 2020 Bond Fund and Center Program Fund, as presented.

Ayes: Abel, Baker, Falah, Hill, Kolin, Southward
Nayes:
Motion Passed: 6/0

C. Request to Approve Bid Pack T9 - District Wide Area Network E-Rate Project

It was moved by Lindsay Baker and supported by Michelle Southward to approve Bid Package T9 - District Wide Area Network E-Rate Project in the amount of \$1,330,747.33, inclusive of 10% contingency, to be paid from the 2020 Bond Fund and Center Program Fund, as presented.

Ayes: Abel, Baker, Falah, Hill, Kolin, Southward
Nayes:
Motion Passed: 6/0

D. Request to Award Bid for Physical Move Services

It was moved by Jason Abel and supported by Paul Kolin to award physical moving services in the total amount of \$523,850.00 as outlined:

- Capricorn Diversified Systems (Technology at Elementaries) \$60,835.00
- Office Moving Alliance Worldwide, LLC (Crates at All Schools) \$61,250.00
- Palmer Moving Services (Bloomin' West, Conant, IA & Way) \$162,762.50
- Premier Locations (Eastover, Lone Pine & Internal Moves) \$191,380.00
- District Project Contingency (10% of Physical Move Cost) \$47,622.50

The total sum covers the moving services for the 2025 summer construction work, and are to be paid using Bond Funds.

Ayes: Abel, Baker, Falah, Hill, Kolin, Southward
Nayes:
Motion Passed: 6/0

E. Request to Adopt Bloomfield Hills High School New Courses and Course Changes for the 2025-26 School Year

It was moved by Tareq Falah and supported by Michelle Southward to approve the changes to the Bloomfield Hills High School course offerings for the 2025-26 school year, pursuant to Board Policy 3001, as presented.

Ayes: Abel, Baker, Falah, Hill, Kolin, Southward
Nayes:
Motion Passed: 6/0

F. Request to Approve First Amendment to the Cooperative Agreement between Bloomfield Hills Schools and Charter Township of West Bloomfield Parks and Recreation Commission - Pine Lake Park

It was moved by Paul Kolin and supported by Tareq Falah to approve the First Amendment to the Cooperative Agreement between Bloomfield Hills Schools and the Charter Township of West Bloomfield Parks and Recreation Commission, as presented.

Ayes: Abel, Baker, Falah, Hill, Kolin, Southward

Nayes:

Motion Passed: 6/0

G. Board Governance and District Operations Overview

Kevin Sutton, Attorney at Miller Johnson, PLC provided an overview on the legal authority, roles and responsibilities, superintendent-board relations, and governance standards as it relates to board governance and district operations.

XI. ADJOURNMENT

There being no further business, President Hill adjourned the meeting at 9:21 p.m.

Respectfully Submitted,

Carolyn Noble
Bloomfield Hills Schools Board Secretary

CN/rc



Bloomfield Hills Board of Education

Memo

To: Superintendent and Board of Education
From: Kandice Moynihan, Assistant Superintendent of Business Services
Date: February 27, 2025
Re: Request to Approve Disbursement Reports

Recommended Motion:

I move the Board of Education to approve the disbursement reports, as presented.

Background Information:

A reference chart is included with the disbursement reports to help navigate the definition of the Fund and Object columns included on the Check and EFT Disbursements files.

ATTACHMENTS:

File Name	Description
☐ Reference_Chart_for_Disbursement_Reports_(rev_1-2021).pdf	Reference Chart for Disbursement Reports
☐ 2.24.25_-_Disbursements_-_January.pdf	January 2025 Disbursement Report

Disbursements Reference Chart

Fund #	Fund - The 3 rd column of the disbursement report
101	<p>General Fund</p> <p>Note: The General Fund is our main fund and accounts for our P-12 activities. We use sub fund #'s to further segregate General Fund activity for analysis purposes. All of the sub fund categories rolls up into the General Fund as a whole. The payment listing identifies the sub fund, which may help further explain the expenditure. The following are subcategories of the General Fund that appear in the payment listing:</p>
	106 Preschools
	108 PREP
	114 Federal grant activities
	124 State grant activities
	210 Athletics
	211 Clubs
220	Center Program
230	Community Services/Recreation
250	Food Services
272	International Academy
402	Capital Improvement Fund
408	Bond Fund
416	Sinking Fund
430	Capital Equipment Fund
510	Scholarship/Trust Funds
610	Hills Funds
810	Internal Service Fund (primarily self-insured activity)

Object #	Object Category – The 4th column of the disbursement report
	Object column has 8 digits. The firsts digit represents the type of account. For the payment listing, it will usually be a “5” for an expenditure/payment. The 2nd digit represents the object category as follows:
51xxxxxx	1 represent salaries/wages through payroll, which is NOT part of the payment
52xxxxxx	2 represent employee benefits
53xxxxxx	3 represents a Purchased Service, such as contracted substitutes and staff, legal/audit/consulting services, police liaisons, officials, etc.
54xxxxxx	4 represent a repair or rental
55xxxxxx	5 represents supplies, such as teaching supplies, energy supplies (gas, electricity, diesel fuel, food, tires, office, etc.
56xxxxxx	6 represents capital outlay. Since the establishment of the Capital Equipment Fund, seeing this category is infrequent, but may occur if someone chose this account for a small purchase that they deemed equipment.
57xxxxxx	7 represents dues, fees, including entry fees, registration fees, taxes abated etc.
58xxxxxx	8 represents payments to other districts, such as outgoing tuition

The payment listing will show some items other than a 5 for expenditures. You may see the following:

2xxxxxxx - this is a liability account that will show up if we are holding money that is refunded, a payroll garnishment or with Hills and Trust activities.

4xxxxxxx - this is a revenue account that will show up if we collected revenue that is refunded.

Bloomfield Hills Schools
Detailed Check Register for Board Reporting
Check Date From 1/1/2025 TO 1/31/2025

PE ID	Vendor Name	Fund	Object	Check#	Check Date	Invoice #	Description	PO#	Amount	Type
00057417	4MYBENEFITS INC	810	53190000	EP 00010495	01/06/2025	28442	Active EEs January 2025		3,276.00	MW
00057417	4MYBENEFITS INC	810	53190000	EP 00010495	01/06/2025	28473	Data Mapping Svcs-New Map DEC		1,250.00	MW
									Vendor Total:	4,526.00
00000211	CENTRAL MICHIGAN PAPER CO	101	55110000	EP 00010496	01/06/2025	56552600	Frantz CMPaper		2,799.00	MW
									Vendor Total:	2,799.00
00007637	DAVIS, MARY	101	55110000	EP 00010497	01/06/2025	REI11212024	Davis Biology Lab (Cell Model)		50.22	MW
									Vendor Total:	50.22
00058139	DYNAMIC TESTING LLC	101	53140000	EP 00010498	01/06/2025	790	ROAD TEST FOR RUFUS THOMAS		200.00	MW
									Vendor Total:	200.00
00017096	EARTH TO EARTH INC	230	55990000	EP 00010499	01/06/2025	60378	SWEATSHIRTS & T-SHIRTS		1,875.00	MW
									Vendor Total:	1,875.00
00032809	EDUSTAFF LLC	101	53113000	EP 00010500	01/06/2025	20250103012	Contracted Subs 12/15-12/28/24		97,868.91	MW
									Vendor Total:	97,868.91
00052314	ELLIS, RALPH	220	53210000	EP 00010501	01/06/2025	MLGDEC2024	DECEMBER 24 MLG		22.11	MW
									Vendor Total:	22.11
00001602	HOEKSTRA TRANSPORTATION INC	101	55730000	EP 00010502	01/06/2025	X10202079601	MISC BUS PARTS		1,675.74	MW
									Vendor Total:	1,675.74
00002204	HOLLYER, LAURA	101	53210000	EP 00010503	01/06/2025	MLGDEC2024	Hollyer (Bowers) Round Trip		20.10	MW
00002204	HOLLYER, LAURA	101	53210000	EP 00010503	01/06/2025	MLGNOV2024	Hollyer (Bowers) Round Trip		20.10	MW
									Vendor Total:	40.20
00058245	HUNT, KATHERINE	220	53210000	EP 00010504	01/06/2025	MLGDEC2024	DECEMBER 24 MLG		47.57	MW
									Vendor Total:	47.57
00057169	LEARNING ALLY INC	101	53450000	EP 00010505	01/06/2025	IN44079	Licensing renewal		12,512.64	MW
									Vendor Total:	12,512.64
00054509	LEEJAN, ANGELA	610	24317070	EP 00010506	01/06/2025	REI12112024	Lee-Jan (Penpal/Club Activ)		127.25	MW
									Vendor Total:	127.25
00057071	MCDONALD, KEITH	101	53210000	EP 00010507	01/06/2025	MLGSEP2024	Sept 2024 Mileage Reimb		57.29	MW
00057071	MCDONALD, KEITH	101	53210000	EP 00010507	01/06/2025	MLGDEC2024	Dec 2024 Mileage Reimb		30.82	MW
00057071	MCDONALD, KEITH	101	53210000	EP 00010507	01/06/2025	MLGOCT2024	Oct 2024 Mileage Reimb		66.06	MW
00057071	MCDONALD, KEITH	101	53210000	EP 00010507	01/06/2025	MLGNOV2024	Nov 2024 Mileage Reimb		69.35	MW
									Vendor Total:	223.52
00056681	MILLER JOHNSON	101	53170000	EP 00010508	01/06/2025	1964470	Legal Fees Jasper Lit		167.00	MW
									Vendor Total:	167.00

User: KMOYNIHAN - Kandice Moynihan

Page

Current Date: 02/19/2025

Report: OSAP5001A - OSAP5001A: Detailed Check Register for

1

Current Time: 17:16:25

Selection:

Vers. 1

OH_DTL.[oh_ck_dt] <= '01/31/2025' AND OH_DTL.[oh_ck_dt] >= '01/01/2025'

Bloomfield Hills Schools
Detailed Check Register for Board Reporting
Check Date From 1/1/2025 TO 1/31/2025

PE ID	Vendor Name	Fund	Object	Check#	Check Date	Invoice #	Description	PO#	Amount	Type
00055742	MONDRAGON, DONNA	101	53210000	EP 00010509	01/06/2025	MLGDEC2024	Dec 2024 Mileage Reimb		3.01	MW
00055742	MONDRAGON, DONNA	101	53210000	EP 00010509	01/06/2025	MLGNOV2024	Nov 2024 Mileage Reimb		4.02	MW
00055742	MONDRAGON, DONNA	101	53210000	EP 00010509	01/06/2025	MLGDEC2024	Dec 2024 Mileage Reimb		3.02	MW
00055742	MONDRAGON, DONNA	101	53210000	EP 00010509	01/06/2025	MLGNOV2024	Nov 2024 Mileage Reimb		4.02	MW
Vendor Total:									14.07	
00057304	OPUS MIME INC	610	24312066	EP 00010510	01/06/2025	SER11212024	Bogrette (Coaching)		240.00	MW
Vendor Total:									240.00	
00058210	SOMMERS, TIFFANY	101	53210000	EP 00010511	01/06/2025	MLGDEC2024	DECEMBER 24 MLG		20.90	MW
Vendor Total:									20.90	
00018782	SPENCER OIL COMPANY	101	55710000	EP 00010512	01/06/2025	30677347	DIESEL FUEL		13,091.14	MW
00018782	SPENCER OIL COMPANY	101	55710000	EP 00010512	01/06/2025	30677346	UNLEADED REGULAR FUEL		3,519.29	MW
Vendor Total:									16,610.43	
00056703	WORRY FREE TRANSPORTATION	101	53310000	EP 00010513	01/06/2025	35387	MISCHOOL4DEAF 12/2-6 TAXI		644.96	MW
Vendor Total:									644.96	
00057052	WROBLEWSKI, LESLIE	101	53210000	EP 00010514	01/06/2025	MLGDEC2024	DECEMBER 24 MLG		75.24	MW
Vendor Total:									75.24	
00057471	ZEPKE, ALIEHS	220	53210000	EP 00010515	01/06/2025	MLGDEC2024	DECEMBER 24 MLG		9.38	MW
Vendor Total:									9.38	
00058292	MILLER, MICHAEL	101	53113000	EP 00010516	01/07/2025	EXP12092024	Summary of Unpaid Wages		105.18	MW
Vendor Total:									105.18	
00058072	ACCESS ABILITY DHH LLC	220	53190000	EP 00010517	01/16/2025	000000432	Supervisor coaching		300.00	MW
Vendor Total:									300.00	
00017025	ALIZADEH, JACQUELYNNE	101	53210000	EP 00010518	01/16/2025	MLGNOV2024	Nov 2024 Mileage Reimb		9.11	MW
00017025	ALIZADEH, JACQUELYNNE	101	53210000	EP 00010518	01/16/2025	MLGNOV2024	Nov 2024 Mileage Reimb		9.11	MW
Vendor Total:									18.22	
00056581	ANDERSON, DALE	610	24311252	EP 00010519	01/16/2025	SER12312024	Clinician Dec 24		1,215.00	MW
Vendor Total:									1,215.00	
00033922	ARAMARK SERVICES INC	250	53190000	EP 00010520	01/16/2025	KC01059197	Labor/Dir Exp/Mgmt Fee		144,035.08	MW
00033922	ARAMARK SERVICES INC	250	55610000	EP 00010520	01/16/2025	KC01059197	Food		134,947.20	MW
00033922	ARAMARK SERVICES INC	250	55640000	EP 00010520	01/16/2025	KC01059197	Non-Food Suppies		6,036.10	MW
00033922	ARAMARK SERVICES INC	250	55640000	EP 00010520	01/16/2025	KC01059197	Freight		126.00	MW
Vendor Total:									285,144.38	
00001813	AVENTRIC TECHNOLOGIES LLC	101	53190000	EP 00010521	01/16/2025	6087174	DISTRICT AED PARTS,		1,789.00	MW

User: KMOYNIHAN - Kandice Moynihan

Page

Current Date: 02/19/2025

Report: OSAP5001A - OSAP5001A: Detailed Check Register for

2

Current Time: 17:16:25

Selection:

Vers. 1

OH_DTL.[oh_ck_dt] <= '01/31/2025' AND OH_DTL.[oh_ck_dt] >= '01/01/2025'

Bloomfield Hills Schools
Detailed Check Register for Board Reporting
Check Date From 1/1/2025 TO 1/31/2025

PE ID	Vendor Name	Fund	Object	Check#	Check Date	Invoice #	Description	PO#	Amount	Type
									Vendor Total:	1,789.00
00055112	BARTERIAN, STEPHANIE	101	53210000	EP 00010522	01/16/2025	MLGDEC2024	DECEMBER 24 MLG		103.18	MW
									Vendor Total:	103.18
00032846	BARTON MALOW COMPANY	408	53198005	EP 00010523	01/16/2025	90122263	MONTHLY TECH DESIGN	P2100072	16,642.31	MW
00032846	BARTON MALOW COMPANY	408	53198001	EP 00010523	01/16/2025	90121399P2100037	NEW ACCT STAFFING PLAN	P2100037	136,282.22	MW
00032846	BARTON MALOW COMPANY	408	53198001	EP 00010523	01/16/2025	90122385P2100037	NEW ACCT STAFFING PLAN	P2100037	136,282.22	MW
00032846	BARTON MALOW COMPANY	408	53198002	EP 00010523	01/16/2025	90121399P2100037	NEW ACCT GEN LIABILITY	P2100037	681.41	MW
00032846	BARTON MALOW COMPANY	408	53198002	EP 00010523	01/16/2025	90122385P2100037	NEW ACCT GEN LIABILITY	P2100037	681.41	MW
00032846	BARTON MALOW COMPANY	408	53198003	EP 00010523	01/16/2025	90121399P2100037	General Conditions Issued at \$	P2100037	521.21	MW
00032846	BARTON MALOW COMPANY	408	53198003	EP 00010523	01/16/2025	90122385P2100037	General Conditions Issued at \$	P2100037	13,627.16	MW
00032846	BARTON MALOW COMPANY	408	56222000	EP 00010523	01/16/2025	90122385P2400138	CO#4 AmMex Eastover 9.24.2024	P2400138	404.51	MW
00032846	BARTON MALOW COMPANY	408	56222000	EP 00010523	01/16/2025	90122385P2400138	CO #3 Ammex Way 9.23.2024	P2400138	175.00	MW
00032846	BARTON MALOW COMPANY	408	56222000	EP 00010523	01/16/2025	90122385P2400138	CO #4 AmMex Lone Pine 9.24.202	P2400138	189.63	MW
00032846	BARTON MALOW COMPANY	408	56222000	EP 00010523	01/16/2025	90122385P2400138	CO #4 AmMex Way 9.24.2024	P2400138	17.21	MW
00032846	BARTON MALOW COMPANY	408	56224000	EP 00010523	01/16/2025	90121399P2400140	BP8.3 BHHS HEALTH & WELLNESS	P2400140	363,473.78	MW
00032846	BARTON MALOW COMPANY	408	56224000	EP 00010523	01/16/2025	90121399P2400140	Omega Floors CO #1 7.18.2024	P2400140	2,619.00	MW
00032846	BARTON MALOW COMPANY	408	56224000	EP 00010523	01/16/2025	90121399P2400140	CO #2 Contrast Mechanical 8/28	P2400140	9,710.24	MW
00032846	BARTON MALOW COMPANY	408	56224000	EP 00010523	01/16/2025	90121399P2400140	CO #2 Omega Floors 9.26.2024	P2400140	-540.00	MW
00032846	BARTON MALOW COMPANY	408	56224000	EP 00010523	01/16/2025	90122385P2400140	BP8.3 BHHS HEALTH & WELLNESS	P2400140	183,751.55	MW
00032846	BARTON MALOW COMPANY	408	56224000	EP 00010523	01/16/2025	90122385P2400140	CO #2 Contrast Mechanical 8/28	P2400140	24,786.91	MW
00032846	BARTON MALOW COMPANY	408	56224000	EP 00010523	01/16/2025	90122385P2400140	CO#2 Arisco 12.19.2024	P2400140	8,071.35	MW
00032846	BARTON MALOW COMPANY	408	56224000	EP 00010523	01/16/2025	90122385P2400140	EZ Electric CO #1 7.18.2024	P2400140	32,745.66	MW
00032846	BARTON MALOW COMPANY	408	56224000	EP 00010523	01/16/2025	90122385P2400140	Contrast CO #1 7.18.2024	P2400140	10,079.55	MW
00032846	BARTON MALOW COMPANY	408	56310000	EP 00010523	01/16/2025	90122385P2400094	Bond Work CO #4 BP6	P2400094	187.50	MW
00032846	BARTON MALOW COMPANY	408	56310000	EP 00010523	01/16/2025	90122385P2300077	BP6 LANDSCAPING 320536	P2300077	6,624.42	MW
00032846	BARTON MALOW COMPANY	408	56310000	EP 00010523	01/16/2025	90122385P2300077	CO #1 8.31.2023	P2300077	402.45	MW
00032846	BARTON MALOW COMPANY	408	56310000	EP 00010523	01/16/2025	90122385P2300077	CO #2 10.25.2023	P2300077	71.50	MW
00032846	BARTON MALOW COMPANY	408	56310000	EP 00010523	01/16/2025	90122385P2300077	CO #3 11/30/2023	P2300077	76.50	MW
00032846	BARTON MALOW COMPANY	408	56310000	EP 00010523	01/16/2025	90122385P2200076	CO #7 Backcharge 1.5.2024	P2200076	-6,504.30	MW
00032846	BARTON MALOW COMPANY	408	56310000	EP 00010523	01/16/2025	90122385P2200071	SHMS SITEWORK SOIL	P2200071	742.50	MW
00032846	BARTON MALOW COMPANY	408	56310000	EP 00010523	01/16/2025	90122385P2200076	CO #6 Deduct 1.5.2024	P2200076	-3,167.10	MW
00032846	BARTON MALOW COMPANY	408	56310000	EP 00010523	01/16/2025	90122385P2200076	CO #8 11/3/2023	P2200076	7,019.10	MW
00032846	BARTON MALOW COMPANY	408	56310000	EP 00010523	01/16/2025	90122385P2200076	CO #7 1.5.2024	P2200076	1,465.20	MW
00032846	BARTON MALOW COMPANY	408	56310000	EP 00010523	01/16/2025	90122385P2200076	CO #9 Backcharge Correction 1.	P2200076	1,187.10	MW

User: KMOYNIHAN - Kandice Moynihan

Page

Current Date: 02/19/2025

Report: OSAP5001A - OSAP5001A: Detailed Check Register for

3

Current Time: 17:16:25

Selection:

Vers. 1

OH_DTL.[oh_ck_dt] <= '01/31/2025' AND OH_DTL.[oh_ck_dt] >= '01/01/2025'

Bloomfield Hills Schools
Detailed Check Register for Board Reporting
Check Date From 1/1/2025 TO 1/31/2025

PE ID	Vendor Name	Fund	Object	Check#	Check Date	Invoice #	Description	PO#	Amount	Type
00032846	BARTON MALOW COMPANY	408	56310000	EP 00010523	01/16/2025	90122385P2300071	CO #1 8.31.2023	P2300071	138.90	MW
00032846	BARTON MALOW COMPANY	408	56310000	EP 00010523	01/16/2025	90122385P2300071	CO #4 1.5.2024	P2300071	204.25	MW
00032846	BARTON MALOW COMPANY	408	56310000	EP 00010523	01/16/2025	90122385P2200076	CO #10 11.20.2024	P2200076	1,080.00	MW
00032846	BARTON MALOW COMPANY	408	56310000	EP 00010523	01/16/2025	90122385P2300071	BP6 LANDSCAPING 320536	P2300071	5,509.18	MW
00032846	BARTON MALOW COMPANY	408	56310000	EP 00010523	01/16/2025	90121399P2400140	BP8.3 HEALTH & WELLNESS SITE	P2400140	4,050.00	MW
00032846	BARTON MALOW COMPANY	408	56310000	EP 00010523	01/16/2025	90122385P2400092	Co #10 Additional work on BP 8	P2400092	41.77	MW
00032846	BARTON MALOW COMPANY	408	56310000	EP 00010523	01/16/2025	90122385P2400092	CO #10 Additional work at high	P2400092	105.41	MW
00032846	BARTON MALOW COMPANY	408	56310000	EP 00010523	01/16/2025	90122385P2400092	CO #11 1.18.2024	P2400092	101.50	MW
00032846	BARTON MALOW COMPANY	408	56310000	EP 00010523	01/16/2025	90122385P2400092	CO #15 6.5.2024	P2400092	164.38	MW
00032846	BARTON MALOW COMPANY	408	56310000	EP 00010523	01/16/2025	90122385P2400140	BP8.3 HEALTH & WELLNESS SITE	P2400140	23,400.00	MW
00032846	BARTON MALOW COMPANY	408	56310000	EP 00010523	01/16/2025	90121399P2500035	FOX HILLS DEMOLITION BID	P2500035	32,220.00	MW
00032846	BARTON MALOW COMPANY	408	56220000	EP 00010523	01/16/2025	90121399P2200059	BID CATEGORY #06000 - GENERAL	P2200059	127,189.99	MW
00032846	BARTON MALOW COMPANY	408	56220000	EP 00010523	01/16/2025	90121399P2200059	CO#1 - CREDIT FOR REMOVAL OF	P2200059	-335.07	MW
00032846	BARTON MALOW COMPANY	408	56220000	EP 00010523	01/16/2025	90121399P2200059	CO #2	P2200059	26.45	MW
00032846	BARTON MALOW COMPANY	408	56220000	EP 00010523	01/16/2025	90121399P2200059	CO#3 8/31/2022	P2200059	2,284.45	MW
00032846	BARTON MALOW COMPANY	408	56220000	EP 00010523	01/16/2025	90121399P2200059	CO #4 11.21.2022	P2200059	1,539.80	MW
00032846	BARTON MALOW COMPANY	408	56220000	EP 00010523	01/16/2025	90121399P2200059	CO #7 1.9.2023	P2200059	111.05	MW
00032846	BARTON MALOW COMPANY	408	56220000	EP 00010523	01/16/2025	90122385P2200063	BID CATEGORY #131500 -	P2200063	5,979.99	MW
00032846	BARTON MALOW COMPANY	408	56220000	EP 00010523	01/16/2025	90122385P2200063	Change Order #1 UV Control Cab	P2200063	20.10	MW
00032846	BARTON MALOW COMPANY	408	56220000	EP 00010523	01/16/2025	90122385P2200063	CO #4 10/25/2023	P2200063	66.79	MW
00032846	BARTON MALOW COMPANY	408	56220000	EP 00010523	01/16/2025	90121399P2200059	CO #10 5/3/2023	P2200059	1,847.85	MW
00032846	BARTON MALOW COMPANY	408	56220000	EP 00010523	01/16/2025	90121399P2200059	CO #11 6.20.2023	P2200059	1,766.85	MW
00032846	BARTON MALOW COMPANY	408	56220000	EP 00010523	01/16/2025	90121399P2200059	CO #13 10/16/2023	P2200059	225.85	MW
00032846	BARTON MALOW COMPANY	408	56220000	EP 00010523	01/16/2025	90121399P2200059	CO #15 11.21.2023 Add	P2200059	1,036.30	MW
00032846	BARTON MALOW COMPANY	408	56220000	EP 00010523	01/16/2025	90121399P2200059	CO #15 Deduct 11.22.2023	P2200059	-62.47	MW
00032846	BARTON MALOW COMPANY	408	56220000	EP 00010523	01/16/2025	90121399P2200059	CO #16 10.25.2024	P2200059	4,188.00	MW
00032846	BARTON MALOW COMPANY	408	56220000	EP 00010523	01/16/2025	90122385P2200080	CO #13 Deduct 10.22.2024	P2200080	-5,400.00	MW
00032846	BARTON MALOW COMPANY	408	56220000	EP 00010523	01/16/2025	90122385P2200080	CO #14 10.22.2024	P2200080	5,892.10	MW
00032846	BARTON MALOW COMPANY	408	56220000	EP 00010523	01/16/2025	90122385P2200069	CO #12 Deduct 1.18.2024	P2200069	-7,181.53	MW
00032846	BARTON MALOW COMPANY	408	56220000	EP 00010523	01/16/2025	90122385P2200069	CO #3	P2200069	328.53	MW
00032846	BARTON MALOW COMPANY	408	56220000	EP 00010523	01/16/2025	90122385P2200069	CO #2	P2200069	453.19	MW
00032846	BARTON MALOW COMPANY	408	56220000	EP 00010523	01/16/2025	90122385P2200080	CO #11 Deduct 10.15.2024	P2200080	-492.10	MW
00032846	BARTON MALOW COMPANY	408	56220000	EP 00010523	01/16/2025	90122385P2200080	CO #12 10.22.2024	P2200080	29,900.70	MW
00032846	BARTON MALOW COMPANY	408	56220000	EP 00010523	01/16/2025	90122385P2200080	CO #12 10.22.2024 Credit	P2200080	-3,312.90	MW
00032846	BARTON MALOW COMPANY	408	56220000	EP 00010523	01/16/2025	90122385P2200080	CO #13 10.22.2024	P2200080	14,999.40	MW

User: KMOYNIHAN - Kandice Moynihan

Page

Current Date: 02/19/2025

Report: OSAP5001A - OSAP5001A: Detailed Check Register for

4

Current Time: 17:16:25

Selection:

Vers. 1

OH_DTL.[oh_ck_dt] <= '01/31/2025' AND OH_DTL.[oh_ck_dt] >= '01/01/2025'

Bloomfield Hills Schools
Detailed Check Register for Board Reporting
Check Date From 1/1/2025 TO 1/31/2025

PE ID	Vendor Name	Fund	Object	Check#	Check Date	Invoice #	Description	PO#	Amount	Type
00032846	BARTON MALOW COMPANY	408	56220000	EP 00010523	01/16/2025	90122385P2200069	Co #10 Labor Backcharge 1.5.20	P2200069	-250.00	MW
00032846	BARTON MALOW COMPANY	408	56220000	EP 00010523	01/16/2025	90122385P2200069	CO #10 1.5.2024 Deduct Allowan	P2200069	-500.00	MW
00032846	BARTON MALOW COMPANY	408	56220000	EP 00010523	01/16/2025	90122385P2200069	CO #9 7/11/2023	P2200069	1,168.48	MW
00032846	BARTON MALOW COMPANY	408	56220000	EP 00010523	01/16/2025	90122385P2200069	CO #8 4.3.2023	P2200069	972.06	MW
00032846	BARTON MALOW COMPANY	408	56220000	EP 00010523	01/16/2025	90122385P2200069	CO #6 Add 11.21.2022	P2200069	1,357.90	MW
00032846	BARTON MALOW COMPANY	408	56220000	EP 00010523	01/16/2025	90122385P2200069	CHANGE ORDER #5 8.2.2022	P2200069	51.69	MW
00032846	BARTON MALOW COMPANY	408	56220000	EP 00010523	01/16/2025	90122385P2200069	CO#1 SHMS	P2200069	641.82	MW
00032846	BARTON MALOW COMPANY	408	56220000	EP 00010523	01/16/2025	90122385P2200069	C2109 BP4 SOUTH HILLS MIDDLE	P2200069	87,039.49	MW
00032846	BARTON MALOW COMPANY	408	56220000	EP 00010523	01/16/2025	90122385P2200069	CO#16 12.19.2024	P2200069	1,707.25	MW
00032846	BARTON MALOW COMPANY	408	56220000	EP 00010523	01/16/2025	90122385P2200069	CO #15 6.5.2024	P2200069	231.31	MW
00032846	BARTON MALOW COMPANY	408	56220000	EP 00010523	01/16/2025	90122385P2200069	CO #13 2.28.2024	P2200069	30.67	MW
00032846	BARTON MALOW COMPANY	408	56220000	EP 00010523	01/16/2025	90122385P2200069	CO #10 1.5.2024 Add	P2200069	1,217.19	MW
00032846	BARTON MALOW COMPANY	408	56220000	EP 00010523	01/16/2025	90122385P2200069	CO #14 4.2.2024	P2200069	197.86	MW
00032846	BARTON MALOW COMPANY	408	56220000	EP 00010523	01/16/2025	90122385P2200069	CO #12 1/18/2024	P2200069	590.67	MW
00032846	BARTON MALOW COMPANY	408	56220000	EP 00010523	01/16/2025	90122385P2200069	CO #11 - 1.8.2024	P2200069	223.80	MW
00032846	BARTON MALOW COMPANY	408	56220000	EP 00010523	01/16/2025	90122385P2200069	CO #7 1.9.2023	P2200069	56.14	MW
00032846	BARTON MALOW COMPANY	408	56220000	EP 00010523	01/16/2025	90122385P2200069	CO #6 Deduct 11.21.2022	P2200069	-45.61	MW
00032846	BARTON MALOW COMPANY	408	56220000	EP 00010523	01/16/2025	90122385P2200069	CO #4 Add	P2200069	4,123.27	MW
00032846	BARTON MALOW COMPANY	408	56220000	EP 00010523	01/16/2025	90121399P2300055	BP6 FLOORING 096500	P2300055	7,450.00	MW
00032846	BARTON MALOW COMPANY	408	56220000	EP 00010523	01/16/2025	90121399P2300055	CO #2 11/27/2023	P2300055	240.00	MW
00032846	BARTON MALOW COMPANY	408	56220000	EP 00010523	01/16/2025	90121399P2300055	CO #3 1.8.2024 Allowance Corre	P2300055	1,000.00	MW
00032846	BARTON MALOW COMPANY	408	56220000	EP 00010523	01/16/2025	90121399P2300055	CO #4 2.12.2024	P2300055	395.74	MW
00032846	BARTON MALOW COMPANY	408	56220000	EP 00010523	01/16/2025	90121399P2300058	BP6 FLOORING 096500	P2300058	7,775.01	MW
00032846	BARTON MALOW COMPANY	408	56220000	EP 00010523	01/16/2025	90121399P2300058	CO #2 Deduct 11/27/2023	P2300058	-50.00	MW
00032846	BARTON MALOW COMPANY	408	56220000	EP 00010523	01/16/2025	90121399P2300058	CO #1 Deduct s/b Here 12.19.20	P2300058	-1,000.01	MW
00032846	BARTON MALOW COMPANY	408	56220000	EP 00010523	01/16/2025	90121399P2300058	CO #3 Deduct Allowance 1.8.202	P2300058	-1,000.00	MW
00032846	BARTON MALOW COMPANY	408	56220000	EP 00010523	01/16/2025	90121399P2300058	CO #4 2.12.2024	P2300058	936.34	MW
00032846	BARTON MALOW COMPANY	408	56220000	EP 00010523	01/16/2025	90121399P2300062	BP6 FLOORING 096500	P2300062	7,535.00	MW
00032846	BARTON MALOW COMPANY	408	56220000	EP 00010523	01/16/2025	90121399P2300062	CO #1 Add 11/3/2023	P2300062	411.71	MW
00032846	BARTON MALOW COMPANY	408	56220000	EP 00010523	01/16/2025	90121399P2300062	CO #2 11/27/2023	P2300062	187.93	MW
00032846	BARTON MALOW COMPANY	408	56220000	EP 00010523	01/16/2025	90121399P2300060	BP6 FLOORING 096500	P2300060	7,715.00	MW
00032846	BARTON MALOW COMPANY	408	56220000	EP 00010523	01/16/2025	90121399P2300060	CO #2 11/27/2023	P2300060	256.78	MW
00032846	BARTON MALOW COMPANY	408	56220000	EP 00010523	01/16/2025	90122385P2400138	BP 9 CONANT BLDG WORK	P2400138	679.01	MW
00032846	BARTON MALOW COMPANY	408	56220000	EP 00010523	01/16/2025	90122385P2400138	Pontiac Ceiling/Nat Door Conan	P2400138	394.20	MW
00032846	BARTON MALOW COMPANY	408	56220000	EP 00010523	01/16/2025	90121399P2400138	BP9 BLDG EASTOVER	P2400138	9,937.50	MW

User: KMOYNIHAN - Kandice Moynihan

Page

Current Date: 02/19/2025

Report: OSAP5001A - OSAP5001A: Detailed Check Register for

5

Current Time: 17:16:25

Selection:

Vers. 1

OH_DTL.[oh_ck_dt] <= '01/31/2025' AND OH_DTL.[oh_ck_dt] >= '01/01/2025'

Bloomfield Hills Schools
Detailed Check Register for Board Reporting
Check Date From 1/1/2025 TO 1/31/2025

PE ID	Vendor Name	Fund	Object	Check#	Check Date	Invoice #	Description	PO#	Amount	Type
00032846	BARTON MALOW COMPANY	408	56220000	EP 00010523	01/16/2025	90121399P2400138	CO #1 Ainsworth Eastover 10.22	P2400138	16,950.25	MW
00032846	BARTON MALOW COMPANY	408	56220000	EP 00010523	01/16/2025	90121399P2400138	CO #2 Ainsworth Eastover 10.22	P2400138	80,090.54	MW
00032846	BARTON MALOW COMPANY	408	56220000	EP 00010523	01/16/2025	90121399P2400138	CO#3 Metro Electric Eastover	P2400138	18,029.98	MW
00032846	BARTON MALOW COMPANY	408	56220000	EP 00010523	01/16/2025	90121399P2400138	CO#3 AINSWORTH EASTOVER	P2400138	15,367.93	MW
00032846	BARTON MALOW COMPANY	408	56220000	EP 00010523	01/16/2025	90121399P2400138	CO#3 AINSWORTH EASTOVER	P2400138	-767.03	MW
00032846	BARTON MALOW COMPANY	408	56220000	EP 00010523	01/16/2025	90122385P2400138	Pontiac Ceiling/Nat Door Easto	P2400138	19,564.60	MW
00032846	BARTON MALOW COMPANY	408	56220000	EP 00010523	01/16/2025	90122385P2400138	CO #1 7.9.2024 Daniels Glass E	P2400138	1,308.76	MW
00032846	BARTON MALOW COMPANY	408	56220000	EP 00010523	01/16/2025	90122385P2300166	CO #1 4.2.2024	P2300166	984.33	MW
00032846	BARTON MALOW COMPANY	408	56220000	EP 00010523	01/16/2025	90121399P2500044	BP6 Shock Brothers CO #5 for w	P2500044	7,060.00	MW
00032846	BARTON MALOW COMPANY	408	56220000	EP 00010523	01/16/2025	90122385P2300165	CO#7 12.20.2024	P2300165	4,923.85	MW
00032846	BARTON MALOW COMPANY	408	56220000	EP 00010523	01/16/2025	90122385P2300166	088000 ALUMINUM ENTRANCES	P2300166	19,667.60	MW
00032846	BARTON MALOW COMPANY	408	56220000	EP 00010523	01/16/2025	90122385P2400138	BP9 BLDG EASTOVER	P2400138	29,227.02	MW
00032846	BARTON MALOW COMPANY	408	56220000	EP 00010523	01/16/2025	90122385P2400138	CO#2 Ammex Eastover	P2400138	280.31	MW
00032846	BARTON MALOW COMPANY	408	56220000	EP 00010523	01/16/2025	90122385P2400138	Pontiac Ceiling/Nat Door Easto	P2400138	-710.01	MW
00032846	BARTON MALOW COMPANY	408	56220000	EP 00010523	01/16/2025	90121399P2400138	BP9 LONE PINE BLDG WORK	P2400138	10,357.20	MW
00032846	BARTON MALOW COMPANY	408	56220000	EP 00010523	01/16/2025	90121399P2400138	CO #1 Ainsworth Lone Pine 10.2	P2400138	6,126.22	MW
00032846	BARTON MALOW COMPANY	408	56220000	EP 00010523	01/16/2025	90121399P2400138	SHOREVIEW ELECTRIC CO #2	P2400138	50,864.55	MW
00032846	BARTON MALOW COMPANY	408	56220000	EP 00010523	01/16/2025	90121399P2400138	CO#3 AINSWORTH LONE PINE A	P2400138	11,237.19	MW
00032846	BARTON MALOW COMPANY	408	56220000	EP 00010523	01/16/2025	90121399P2400138	CO#3 AINSWORTH LONE PINE	P2400138	-548.71	MW
00032846	BARTON MALOW COMPANY	408	56220000	EP 00010523	01/16/2025	90121399P2400138	BP9 WAY BUILDING	P2400138	49,095.00	MW
00032846	BARTON MALOW COMPANY	408	56220000	EP 00010523	01/16/2025	90122385P2400138	BP9 WAY BUILDING	P2400138	6,186.50	MW
00032846	BARTON MALOW COMPANY	408	56220000	EP 00010523	01/16/2025	90122385P2400138	CO#2 Ammex Way	P2400138	146.66	MW
00032846	BARTON MALOW COMPANY	408	56220000	EP 00010523	01/16/2025	90122385P2400138	CO #1 7.9.2024 Daniels Glass L	P2400138	472.04	MW
00032846	BARTON MALOW COMPANY	408	56220000	EP 00010523	01/16/2025	90122385P2400138	CO #1 AmMex Painting & Mainten	P2400138	20.00	MW
00032846	BARTON MALOW COMPANY	408	56220000	EP 00010523	01/16/2025	90122385P2400138	Pontiac Ceiling/Nat Door Lone	P2400138	2,827.10	MW
00032846	BARTON MALOW COMPANY	408	56220000	EP 00010523	01/16/2025	90122385P2400138	Pontiac Ceiling/Nat Door Lone	P2400138	-454.50	MW
00032846	BARTON MALOW COMPANY	408	56220000	EP 00010523	01/16/2025	90122385P2400138	CO#5 AmMex Painting Lone Pine	P2400138	2,583.84	MW
00032846	BARTON MALOW COMPANY	408	56220000	EP 00010523	01/16/2025	90122385P2400138	BP9 LONE PINE BLDG WORK	P2400138	5,411.70	MW
Vendor Total:									1,694,377.03	
00057835	BLANCHARD, KATHLYN	610	24311252	EP 00010524	01/16/2025	SER12312024	Clinician Dec 24		300.00	MW
Vendor Total:									300.00	
00057721	BLOOMFIELD BOOSTERS	610	24314199	EP 00010525	01/16/2025	BSTR419901082025	Rec Equest Boosters Fund Tfr 1		1,644.03	MW
Vendor Total:									1,644.03	
00058033	BLOOMFIELD HILLS ROBOTICS	610	24312333	EP 00010526	01/16/2025	ROBOTICFINALPO	Final Payout		71,331.85	MW

User: KMOYNIHAN - Kandice Moynihan

Page

Current Date: 02/19/2025

Report: OSAP5001A - OSAP5001A: Detailed Check Register for

6

Current Time: 17:16:25

Selection:

Vers. 1

OH_DTL.[oh_ck_dt] <= '01/31/2025' AND OH_DTL.[oh_ck_dt] >= '01/01/2025'

Bloomfield Hills Schools
Detailed Check Register for Board Reporting
Check Date From 1/1/2025 TO 1/31/2025

PE ID	Vendor Name	Fund	Object	Check#	Check Date	Invoice #	Description	PO#	Amount	Type
								Vendor Total:	71,331.85	
00057774	BOTTIGLIA HOOF CARE LLC	101	53190000	EP 00010527	01/16/2025	012501	CORRECTIONAL SHOERING		180.00	MW
								Vendor Total:	180.00	
00058009	BRAINSRING	124	53110000	EP 00010528	01/16/2025	INV10013	Dec.2024 Tutoring		462.00	MW
								Vendor Total:	462.00	
00058119	BRIGHTER SOLUTIONS	124	53190000	EP 00010529	01/16/2025	104	Improving Inst. Literacy 35j		3,937.50	MW
								Vendor Total:	3,937.50	
00057395	BRISKER, BRITTANI	220	53210000	EP 00010530	01/16/2025	MLGDEC2024	December's Mileage		1.27	MW
								Vendor Total:	1.27	
00033907	BROOKES BUNCH	230	53190000	EP 00010531	01/16/2025	232124D02	Girls Glam Unicorn Spa		324.00	MW
								Vendor Total:	324.00	
00006401	BROWN, LISA	101	53210000	EP 00010532	01/16/2025	MLGDEC2024	DECEMBER 24 MLG		172.39	MW
								Vendor Total:	172.39	
00000211	CENTRAL MICHIGAN PAPER CO	101	55110000	EP 00010533	01/16/2025	56580600	Wht 20# Paper Purchase		359.00	MW
00000211	CENTRAL MICHIGAN PAPER CO	101	55110000	EP 00010533	01/16/2025	56681100	CMP Invoice Eastover 1/10/25		1,320.00	MW
00000211	CENTRAL MICHIGAN PAPER CO	101	53610000	EP 00010533	01/16/2025	56771900	Palette of paper		1,320.00	MW
00000211	CENTRAL MICHIGAN PAPER CO	101	55110000	EP 00010533	01/16/2025	56612600	Teaching/Testing Supplies		1,320.00	MW
								Vendor Total:	4,319.00	
00032516	COMPONE ADMINISTRATORS INC	810	53190000	EP 00010534	01/16/2025	182291	Loss Fund Reimb Dec 2024		17,593.66	MW
								Vendor Total:	17,593.66	
00034019	CONSTELLATION ENERGY	272	55510000	EP 00010535	01/16/2025	4210938	90467		394.32	MW
00034019	CONSTELLATION ENERGY	220	55510000	EP 00010535	01/16/2025	4210938	93099		279.00	MW
00034019	CONSTELLATION ENERGY	101	55510000	EP 00010535	01/16/2025	4210938	76922992		4,627.68	MW
00034019	CONSTELLATION ENERGY	101	55510000	EP 00010535	01/16/2025	4210938	56146561		9,099.12	MW
00034019	CONSTELLATION ENERGY	101	55510000	EP 00010535	01/16/2025	4210938	4098		33.48	MW
00034019	CONSTELLATION ENERGY	101	55510000	EP 00010535	01/16/2025	4210938	4361		37.20	MW
00034019	CONSTELLATION ENERGY	101	55510000	EP 00010535	01/16/2025	4210938	50811800		4,516.08	MW
00034019	CONSTELLATION ENERGY	101	55510000	EP 00010535	01/16/2025	4210938	6204665		3,147.12	MW
00034019	CONSTELLATION ENERGY	101	55510000	EP 00010535	01/16/2025	4210938	9836964		933.72	MW
00034019	CONSTELLATION ENERGY	101	55510000	EP 00010535	01/16/2025	4210938	91440		677.04	MW
00034019	CONSTELLATION ENERGY	101	55510000	EP 00010535	01/16/2025	4210938	3016		334.80	MW
00034019	CONSTELLATION ENERGY	101	55510000	EP 00010535	01/16/2025	4210938	9433		55.80	MW
00034019	CONSTELLATION ENERGY	101	55510000	EP 00010535	01/16/2025	4210938	92489		89.28	MW

User: KMOYNIHAN - Kandice Moynihan

Page

Current Date: 02/19/2025

Report: OSAP5001A - OSAP5001A: Detailed Check Register for

7

Current Time: 17:16:25

Selection:

Vers. 1

OH_DTL.[oh_ck_dt] <= '01/31/2025' AND OH_DTL.[oh_ck_dt] >= '01/01/2025'

Bloomfield Hills Schools
Detailed Check Register for Board Reporting
Check Date From 1/1/2025 TO 1/31/2025

PE ID	Vendor Name	Fund	Object	Check#	Check Date	Invoice #	Description	PO#	Amount	Type
00034019	CONSTELLATION ENERGY	101	55510000	EP 00010535	01/16/2025	4210938	93081		44.64	MW
00034019	CONSTELLATION ENERGY	101	55510000	EP 00010535	01/16/2025	4210938	1770		74.40	MW
00034019	CONSTELLATION ENERGY	101	55510000	EP 00010535	01/16/2025	4210938	92430		74.40	MW
00034019	CONSTELLATION ENERGY	101	55510000	EP 00010535	01/16/2025	4210938	92448		18.60	MW
00034019	CONSTELLATION ENERGY	101	55510000	EP 00010535	01/16/2025	4210938	1606		874.20	MW
00034019	CONSTELLATION ENERGY	101	55510000	EP 00010535	01/16/2025	4210938	1036		1,302.00	MW
00034019	CONSTELLATION ENERGY	101	55510000	EP 00010535	01/16/2025	4210938	90848		1,112.28	MW
00034019	CONSTELLATION ENERGY	101	55510000	EP 00010535	01/16/2025	4210938	50802966		4,211.04	MW
00034019	CONSTELLATION ENERGY	101	55510000	EP 00010535	01/16/2025	4210938	8453539		1,502.88	MW
Vendor Total:									33,439.08	
00020787	COWDREY, MIKE	230	55990000	EP 00010536	01/16/2025	REI01072025	Reimburse Costco 1/7/25		77.34	MW
Vendor Total:									77.34	
00052868	D A CENTRAL INC	101	53190000	EP 00010537	01/16/2025	27867	Intercom Service		310.00	MW
Vendor Total:									310.00	
00014354	DEAF COMMUNITY ADVOCACY	220	53190000	EP 00010538	01/16/2025	9639	Interpreting services		500.92	MW
00014354	DEAF COMMUNITY ADVOCACY	220	53190000	EP 00010538	01/16/2025	9445	Interpreting srvs for student		500.61	MW
Vendor Total:									1,001.53	
00053295	DENI ROSE	220	53210000	EP 00010539	01/16/2025	MLGDEC2024	DECEMBER 24 MLG		242.54	MW
Vendor Total:									242.54	
00055236	DIGITAL SIGNUP	272	53450000	EP 00010540	01/16/2025	16017	ENRICHMENT WEBSITE		754.00	MW
Vendor Total:									754.00	
00052692	DIRECT ENERGY BUSINESS	272	55520000	EP 00010541	01/16/2025	243460055883165	I.A. 1020 E Sq Lk Rd		2,380.01	MW
00052692	DIRECT ENERGY BUSINESS	101	55520000	EP 00010541	01/16/2025	243460055883165	Conant 4100 Quarton		2,182.01	MW
00052692	DIRECT ENERGY BUSINESS	101	55520000	EP 00010541	01/16/2025	243460055883165	Eastover 2800 Kensington		3,289.04	MW
00052692	DIRECT ENERGY BUSINESS	101	55520000	EP 00010541	01/16/2025	243460055883165	Way 765 W Long Lk		1,760.20	MW
00052692	DIRECT ENERGY BUSINESS	101	55520000	EP 00010541	01/16/2025	243460055883165	Fox Hills 1661 Hunters Ridge		513.23	MW
00052692	DIRECT ENERGY BUSINESS	101	55520000	EP 00010541	01/16/2025	243460055883165	Doyle Center/Booth Center 7273		1,757.13	MW
00052692	DIRECT ENERGY BUSINESS	101	55520000	EP 00010541	01/16/2025	243460055883165	Bowers School House 1219 E Sq		1,231.63	MW
00052692	DIRECT ENERGY BUSINESS	101	55520000	EP 00010541	01/16/2025	243460055883165	Old EO 1101 Westview		1,392.07	MW
00052692	DIRECT ENERGY BUSINESS	101	55520000	EP 00010541	01/16/2025	243460055883165	Transportation 2780 Kensington		171.53	MW
00052692	DIRECT ENERGY BUSINESS	101	55520000	EP 00010541	01/16/2025	243460055883165	Old Lone Pine 3100 Lone Pine		1,839.91	MW
00052692	DIRECT ENERGY BUSINESS	101	55520000	EP 00010541	01/16/2025	243460055883165	Lone Pine 2601 Lone Pine		3,411.82	MW
00052692	DIRECT ENERGY BUSINESS	101	55520000	EP 00010541	01/16/2025	243460055883165	NHMS 3456 Lahser		6,104.79	MW
00052692	DIRECT ENERGY BUSINESS	101	55520000	EP 00010541	01/16/2025	243460055883165	SHMS 4200 Quarton		3,381.77	MW

User: KMOYNIHAN - Kandice Moynihan

Page

Current Date: 02/19/2025

Report: OSAP5001A - OSAP5001A: Detailed Check Register for

8

Current Time: 17:16:25

Selection:

Vers. 1

OH_DTL.[oh_ck_dt] <= '01/31/2025' AND OH_DTL.[oh_ck_dt] >= '01/01/2025'

Bloomfield Hills Schools
Detailed Check Register for Board Reporting
Check Date From 1/1/2025 TO 1/31/2025

PE ID	Vendor Name	Fund	Object	Check#	Check Date	Invoice #	Description	PO#	Amount	Type
00052692	DIRECT ENERGY BUSINESS	101	55520000	EP 00010541	01/16/2025	243460055883165	Dublin Bldg 4174 Dublin		116.53	MW
00052692	DIRECT ENERGY BUSINESS	101	55520000	EP 00010541	01/16/2025	243460055883165	BHHS 4200 Andover		16,692.53	MW
Vendor Total:									46,224.20	
00057083	DRIVERGENT TRANSPORTATION	610	24318042	EP 00010542	01/16/2025	4131	Les Mis Transportation		1,020.00	MW
00057083	DRIVERGENT TRANSPORTATION	610	24312268	EP 00010542	01/16/2025	4132	Transportation fee		900.00	MW
Vendor Total:									1,920.00	
00032809	EDUSTAFF LLC	101	53113000	EP 00010543	01/16/2025	20250117013	Contracted Subs 12/29-1/11/25		83,939.15	MW
Vendor Total:									83,939.15	
00058003	EHRESMAN ARCHITECTS	416	56220000	EP 00010544	01/16/2025	10	WAY/EO ROOF PROJECT #1824		117.50	MW
00058003	EHRESMAN ARCHITECTS	416	56220000	EP 00010544	01/16/2025	2WAYEO	EO ROOF PROJECT 6524		4,347.54	MW
00058003	EHRESMAN ARCHITECTS	416	56220000	EP 00010544	01/16/2025	10	WAY/EO ROOF PROJECT 1824		117.50	MW
00058003	EHRESMAN ARCHITECTS	416	56220000	EP 00010544	01/16/2025	2WAYEO	WAY ROOF PROJECT 6524		4,347.54	MW
Vendor Total:									8,930.08	
00033905	EXECUTIVE ENERGY SERVICES	101	53190000	EP 00010545	01/16/2025	4798	ENERGY CONSULT SERV NOV 2024		550.00	MW
Vendor Total:									550.00	
00057446	FIEBKE-LANG, MICHELLE	610	24317001	EP 00010546	01/16/2025	REI01062025	Supplies for Staff Meeting		66.18	MW
Vendor Total:									66.18	
00057306	GLAZER, DEBORAH	101	53210000	EP 00010547	01/16/2025	MLGDEC2024	Dec 2024 Mileage Reimb		32.16	MW
Vendor Total:									32.16	
00058069	GMB ARCHITECTURE +	408	53198000	EP 00010548	01/16/2025	5648208	PROFESSIONAL SERVICES	P2400130	565.00	MW
Vendor Total:									565.00	
00057523	GRADUATION ALLIANCE INC	101	53710000	EP 00010549	01/16/2025	GA76836	Jan. 2025 STD & Opt. Stu Recov		8,967.42	MW
Vendor Total:									8,967.42	
00002525	H V BURTON COMPANY	101	55991000	EP 00010550	01/16/2025	39603	CONANT & LP HVAC/BOILER		1,054.40	MW
Vendor Total:									1,054.40	
00007479	HARTMAN, TIFFANY	101	53210000	EP 00010551	01/16/2025	MLGDEC2024	DECEMBER 24 MLG		10.45	MW
Vendor Total:									10.45	
00056599	HEARIT, KATELYN	220	53210000	EP 00010552	01/16/2025	MLGDEC2024	DECEMBER 24 MLG		85.16	MW
Vendor Total:									85.16	
00001602	HOEKSTRA TRANSPORTATION INC	101	55730000	EP 00010553	01/16/2025	X10202092701	DOOR IGNITION KEY		10.92	MW
Vendor Total:									10.92	
00057233	HUYGHE, KAREN	101	55990000	EP 00010554	01/16/2025	REI01062025	JAN 2024 REIMB DILLYBEAN		60.00	MW
Vendor Total:									60.00	

User: KMOYNIHAN - Kandice Moynihan

Page

Current Date: 02/19/2025

Report: OSAP5001A - OSAP5001A: Detailed Check Register for

9

Current Time: 17:16:25

Selection:

Vers. 1

OH_DTL.[oh_ck_dt] <= '01/31/2025' AND OH_DTL.[oh_ck_dt] >= '01/01/2025'

Bloomfield Hills Schools
Detailed Check Register for Board Reporting
Check Date From 1/1/2025 TO 1/31/2025

PE ID	Vendor Name	Fund	Object	Check#	Check Date	Invoice #	Description	PO#	Amount	Type
00058274	I LOGO IT	610	24317006	EP 00010555	01/16/2025	0000001	PJ pants for 8th grade		2,483.85	MW
Vendor Total:									2,483.85	
00054232	INTERIM OF OAKLAND COUNTY	220	53130000	EP 00010556	01/16/2025	252126	Nursing srvc for DHH student		3,289.00	MW
Vendor Total:									3,289.00	
00001731	INTL BACCALAUREATE NORTH	101	57410000	EP 00010557	01/16/2025	INV000144388	Lone Pine PYP 9/2024 - 8/2025		9,260.00	MW
00001731	INTL BACCALAUREATE NORTH	101	57410000	EP 00010557	01/16/2025	INV000144451	Conant PYP 9/2024 - 8/2025		9,260.00	MW
00001731	INTL BACCALAUREATE NORTH	101	57410000	EP 00010557	01/16/2025	1458060	PYP Eval April 24-26, 2023 Con		2,960.00	MW
00001731	INTL BACCALAUREATE NORTH	610	24317031	EP 00010557	01/16/2025	INV000182854	SUBJECT FEES (PER CANDIDATE)		246.00	MW
00001731	INTL BACCALAUREATE NORTH	610	24317031	EP 00010557	01/16/2025	INV000182854	Late Subject Fee (Plizga)		78.00	MW
Vendor Total:									21,804.00	
00056758	KAUKAB LLC	230	53190000	EP 00010558	01/16/2025	202424D03	Messy Fun		660.00	MW
00056758	KAUKAB LLC	230	53190000	EP 00010558	01/16/2025	215524D04	LED Class		360.00	MW
00056758	KAUKAB LLC	230	53190000	EP 00010558	01/16/2025	215524D03	LED's Circuits & Conductivity		540.00	MW
Vendor Total:									1,560.00	
00058120	KEY CODE MEDIA INC	408	56221000	EP 00010559	01/16/2025	121494	BROADCAST SYSTEMS BOE	P2500022	8,709.40	MW
00058120	KEY CODE MEDIA INC	408	56221000	EP 00010559	01/16/2025	124044	BROADCAST SYSTEMS BOE	P2500022	203.31	MW
Vendor Total:									8,912.71	
00057859	KRAUT, WENDY	101	53210000	EP 00010560	01/16/2025	MLGDEC2024	DECEMBER 24 MLG		27.34	MW
Vendor Total:									27.34	
00024238	KREFT, ALISON	220	53210000	EP 00010561	01/16/2025	MLGDEC2024	DECEMBER 24 MLG		156.65	MW
Vendor Total:									156.65	
00054990	LIVERPOOL FC	230	53190000	EP 00010562	01/16/2025	200724D03	Liverpool Reds Soccer		1,937.50	MW
00054990	LIVERPOOL FC	230	53190000	EP 00010562	01/16/2025	200724D04	Liverpool Soccer		1,875.00	MW
Vendor Total:									3,812.50	
00033682	METRO CONTROLS INC	101	53190000	EP 00010563	01/16/2025	C002446	CONTRACT BILL 6 OF 12		937.67	MW
00033682	METRO CONTROLS INC	101	53190000	EP 00010563	01/16/2025	W19251	BLOOMIN E-HVAC CONTROLS		655.00	MW
Vendor Total:									1,592.67	
00056681	MILLER JOHNSON	101	53170000	EP 00010564	01/16/2025	1968879	Legal Fees-Labor & Employment		65.00	MW
00056681	MILLER JOHNSON	101	53170000	EP 00010564	01/16/2025	1968879	Legal Fees - School Law		130.00	MW
00056681	MILLER JOHNSON	101	53170000	EP 00010564	01/16/2025	1968879	Legal Fees Jasper Complaint		325.00	MW
00056681	MILLER JOHNSON	101	53170000	EP 00010564	01/16/2025	1964471	Legal Fees Labor & Employment		2,241.00	MW
00056681	MILLER JOHNSON	101	53170000	EP 00010564	01/16/2025	1964471	Legal Fees School Law		567.00	MW
Vendor Total:									3,328.00	

User: KMOYNIHAN - Kandice Moynihan

Page

Current Date: 02/19/2025

Report: OSAP5001A - OSAP5001A: Detailed Check Register for

10

Current Time: 17:16:25

Selection:

Vers. 1

OH_DTL.[oh_ck_dt] <= '01/31/2025' AND OH_DTL.[oh_ck_dt] >= '01/01/2025'

Bloomfield Hills Schools
Detailed Check Register for Board Reporting
Check Date From 1/1/2025 TO 1/31/2025

PE ID	Vendor Name	Fund	Object	Check#	Check Date	Invoice #	Description	PO#	Amount	Type
00002667	OAKLAND SCHOOLS	101	53450000	EP 00010565	01/16/2025	A0003077	2024-25 Frontline/OHRC		7,779.07	MW
Vendor Total:									7,779.07	
00058249	OLIVER, SARAH	610	24311252	EP 00010566	01/16/2025	SER12312024	Clinician Dec 24 - Harp		325.00	MW
Vendor Total:									325.00	
00057213	P.A.S. CONSULTANTS LLC	124	53190000	EP 00010567	01/16/2025	SER01102025	Director-Public Safety 24/25		2,250.00	MW
Vendor Total:									2,250.00	
00058301	PALMER MOVING AND STORAGE	101	55990000	EP 00010568	01/16/2025	95783	Crate Dollys and Purchase		700.00	MW
Vendor Total:									700.00	
00058237	PAYE, EMILY	610	24311252	EP 00010569	01/16/2025	SER12312024	Clinician Dec 24		360.00	MW
Vendor Total:									360.00	
00057786	PETERSON, CHRISTINE	101	53330000	EP 00010570	01/16/2025	MLGDEC2024	DECEMBER 24 MLG		393.96	MW
00057786	PETERSON, CHRISTINE	101	53330000	EP 00010570	01/16/2025	MLGNOV2024	NOVEMBER 24 MLG		365.82	MW
Vendor Total:									759.78	
00057171	PHELPS, ROBERT	101	53220000	EP 00010571	01/16/2025	CONF12042024	MEMPSA CONFERENCE		500.20	MW
Vendor Total:									500.20	
00007288	PHILLIPS, MEGAN	610	24317097	EP 00010572	01/16/2025	MLGDEC2024	Mileage Reimbursement		50.65	MW
Vendor Total:									50.65	
00032094	PLANTE MORAN REALPOINT LLC	408	53198004	EP 00010573	01/16/2025	10360011	OWNERS REP REIMBURSABLE	P2100084	294.75	MW
00032094	PLANTE MORAN REALPOINT LLC	408	53198004	EP 00010573	01/16/2025	10360011	Amendment 1 (179,250) and 2 (2	P2100084	51,000.00	MW
00032094	PLANTE MORAN REALPOINT LLC	408	53198004	EP 00010573	01/16/2025	10360011	Amendment 3 Moving Services an	P2100084	23.84	MW
Vendor Total:									51,318.59	
00014282	REALLY GOOD STUFF LLC	124	55110000	EP 00010574	01/16/2025	8671478	Large Basket BOHO 6 pack Item	P2500028	9,116.00	MW
00014282	REALLY GOOD STUFF LLC	124	55110000	EP 00010574	01/16/2025	8690725	Large Basket BOHO 6 pack Item	P2500028	6,882.58	MW
00014282	REALLY GOOD STUFF LLC	124	55110000	EP 00010574	01/16/2025	8698548	Large Basket BOHO 6 pack Item	P2500028	2,233.42	MW
Vendor Total:									18,232.00	
00006783	REED, DAVID A	610	24311252	EP 00010575	01/16/2025	SER12312024	Clinician Dec 24		600.00	MW
Vendor Total:									600.00	
00057776	RISK PROGRAM	408	53198003	EP 00010576	01/16/2025	5425335	Builders Risk Ins Pol BP11/13		11,247.00	MW
Vendor Total:									11,247.00	
00057765	RITE-WAY SERVICE INC	101	54120000	EP 00010577	01/16/2025	31530	ICE MACHINE MAINTENANCE		480.96	MW
Vendor Total:									480.96	
00058114	SEASONAL SUNDRIES	230	55990000	EP 00010578	01/16/2025	SSBF004	CONSIGNMENT - SACHETS		21.00	MW
Vendor Total:									21.00	

User: KMOYNIHAN - Kandice Moynihan

Page

Current Date: 02/19/2025

Report: OSAP5001A - OSAP5001A: Detailed Check Register for

11

Current Time: 17:16:25

Selection:

Vers. 1

OH_DTL.[oh_ck_dt] <= '01/31/2025' AND OH_DTL.[oh_ck_dt] >= '01/01/2025'

Bloomfield Hills Schools
Detailed Check Register for Board Reporting
Check Date From 1/1/2025 TO 1/31/2025

PE ID	Vendor Name	Fund	Object	Check#	Check Date	Invoice #	Description	PO#	Amount	Type
00033258	SEATON ATHLETICS LLC	230	53190000	EP 00010579	01/16/2025	210424D03	Seaton Basketball		1,080.00	MW
00033258	SEATON ATHLETICS LLC	230	53190000	EP 00010579	01/16/2025	210424D04	Seaton Basketball		720.00	MW
Vendor Total:									1,800.00	
00007157	SEIPKE BROWN, ERIN	220	53210000	EP 00010580	01/16/2025	MLGDEC2024	DECEMBER 24 MLG		37.79	MW
Vendor Total:									37.79	
00057278	SHADE MASTERS INC	101	55110000	EP 00010581	01/16/2025	1026	Small spaces		4,100.00	MW
Vendor Total:									4,100.00	
00056545	SMITH, MARLA	610	24311252	EP 00010582	01/16/2025	SER12312024	Clinician Dec 24		240.00	MW
Vendor Total:									240.00	
00057719	STAGE, JESSICA	101	53210000	EP 00010583	01/16/2025	MLGNOV2024	Mileage Reimbursement		37.25	MW
Vendor Total:									37.25	
00058298	STRAGER, AARON	101	55110000	EP 00010584	01/16/2025	REI11182024	Strager (Math) EAI		19.45	MW
Vendor Total:									19.45	
00054982	STUART, ELIZABETH	220	53210000	EP 00010585	01/16/2025	MLGDEC2024	DECEMBER 24 MLG		35.51	MW
Vendor Total:									35.51	
00032136	BOLDI	220	53190000	EP 00010586	01/16/2025	INV193	OT services for DHH student		2,349.75	MW
Vendor Total:									2,349.75	
00006607	THE ROOSTERTAIL INC	610	24316386	EP 00010587	01/16/2025	25017C	STUCO Prom 2025 Payment 4		5,000.00	MW
00006607	THE ROOSTERTAIL INC	610	24317165	EP 00010587	01/16/2025	25017B	STUCO Prom 2025 Payment 3		5,000.00	MW
Vendor Total:									10,000.00	
00003495	THRUN LAW FIRM PC	101	53170000	EP 00010588	01/16/2025	301036	General Legal 12/9/24		162.50	MW
00003495	THRUN LAW FIRM PC	101	53170000	EP 00010588	01/16/2025	301603	Annual Legal Retainer		2,500.00	MW
Vendor Total:									2,662.50	
00033821	TK ELEVATOR CORPORATION	101	54110000	EP 00010589	01/16/2025	3008302476	BHHS ELEV SVCE JAN-MAR 2025		3,942.41	MW
Vendor Total:									3,942.41	
00003880	WEST BLOOMFIELD CHAMBER OF	101	57410000	EP 00010590	01/16/2025	102600	Lg Business Membership Renewal		560.00	MW
Vendor Total:									560.00	
00058144	WEST WOODWARD ANIMAL	101	55990000	EP 00010591	01/16/2025	30991	THERAPY DOG MARGE VACCINE		469.07	MW
Vendor Total:									469.07	
00056703	WORRY FREE TRANSPORTATION	101	53310000	EP 00010592	01/16/2025	35435	MISCHOOL4DEAF 12/9-12/13		644.96	MW
00056703	WORRY FREE TRANSPORTATION	101	53310000	EP 00010592	01/16/2025	35487	MISCHOOL4DEAF 12/16-12/20		790.96	MW
Vendor Total:									1,435.92	
00033884	ZONAR SYSTEMS INC	101	55113000	EP 00010593	01/16/2025	INV651531	1/01-3/31/25 GPS/TABLET SVC		7,704.22	MW

User: KMOYNIHAN - Kandice Moynihan

Page

Current Date: 02/19/2025

Report: OSAP5001A - OSAP5001A: Detailed Check Register for

12

Current Time: 17:16:25

Selection:

Vers. 1

OH_DTL.[oh_ck_dt] <= '01/31/2025' AND OH_DTL.[oh_ck_dt] >= '01/01/2025'

Bloomfield Hills Schools
Detailed Check Register for Board Reporting
Check Date From 1/1/2025 TO 1/31/2025

PE ID	Vendor Name	Fund	Object	Check#	Check Date	Invoice #	Description	PO#	Amount	Type
Vendor Total:									7,704.22	
00058147	MICHIGAN EDUCATION	101	24513315	EP 00010594	01/16/2025	2857/2501020	PAYROLL		221.97	MW
00058147	MICHIGAN EDUCATION	101	24513315	EP 00010594	01/16/2025	2855/2501020	PAYROLL		13,928.09	MW
00058147	MICHIGAN EDUCATION	101	24513315	EP 00010594	01/16/2025	2856/2501020	PAYROLL		578.48	MW
Vendor Total:									14,728.54	
00052268	LOCKHART, LISA	101	53210000	EP 00010595	01/16/2025	MLGDEC2024	December Mileage		29.88	MW
Vendor Total:									29.88	
00057937	281 ENTERPRISE COURT LLC	101	54210000	EP 00010596	01/30/2025	02012025RENT	281 ENTERPRISE LEASE Feb 2025 P2400108		5,035.00	MW
Vendor Total:									5,035.00	
00017025	ALIZADEH, JACQUELYNNE	101	53210000	EP 00010597	01/30/2025	MLGDEC2024	Dec 2024 Mileage Reimb		22.78	MW
00017025	ALIZADEH, JACQUELYNNE	101	53210000	EP 00010597	01/30/2025	MLGDEC2024	Dec 2024 Mileage Reimb		22.78	MW
Vendor Total:									45.56	
00001813	AVENTRIC TECHNOLOGIES LLC	101	53190000	EP 00010598	01/30/2025	6087738	DISTRICT AED MAINT & SUPPLIES		3,712.00	MW
Vendor Total:									3,712.00	
00058119	BRIGHTER SOLUTIONS	124	53190000	EP 00010599	01/30/2025	106	Improving Inst. Literacy 35j		2,800.00	MW
Vendor Total:									2,800.00	
00033907	BROOKES BUNCH	230	53190000	EP 00010600	01/30/2025	294324D01	Pickleball - Lone Pine		969.00	MW
00033907	BROOKES BUNCH	230	53190000	EP 00010600	01/30/2025	294324D02	Pickleball - Conant		435.00	MW
00033907	BROOKES BUNCH	230	53190000	EP 00010600	01/30/2025	294324D03	Pickleball at Eastover		217.50	MW
00033907	BROOKES BUNCH	230	53190000	EP 00010600	01/30/2025	248024D03	All Star Cheer		565.00	MW
00033907	BROOKES BUNCH	230	53190000	EP 00010600	01/30/2025	248024D01	All Star Cheer		346.50	MW
00033907	BROOKES BUNCH	230	53190000	EP 00010600	01/30/2025	248024D04	All Star Cheer		297.00	MW
00033907	BROOKES BUNCH	230	53190000	EP 00010600	01/30/2025	248024D02	All Star Cheer		215.00	MW
00033907	BROOKES BUNCH	230	53190000	EP 00010600	01/30/2025	2480ADD24D03	Additional Tumbling		276.00	MW
00033907	BROOKES BUNCH	230	53190000	EP 00010600	01/30/2025	2480ADV24D01	Adv All Star Cheer		594.00	MW
00033907	BROOKES BUNCH	230	53190000	EP 00010600	01/30/2025	216324D03	Schools Out Camp 11/27		295.00	MW
00033907	BROOKES BUNCH	230	53190000	EP 00010600	01/30/2025	216324D03	Schools Out Camp 11/27		98.00	MW
00033907	BROOKES BUNCH	230	53190000	EP 00010600	01/30/2025	2163AM24D03	Schools Out Camp AM Care 11/27		10.00	MW
Vendor Total:									4,318.00	
00058306	BROWN CITY ELEVATOR INC	101	55990000	EP 00010601	01/30/2025	267827	ANIMAL FEED		830.00	MW
Vendor Total:									830.00	
00057537	CATCH TRANSPORT LLC	610	24317075	EP 00010602	01/30/2025	58696	Bogrette (Festival Bay City)		4,500.00	MW
Vendor Total:									4,500.00	

User: KMOYNIHAN - Kandice Moynihan

Page

Current Date: 02/19/2025

Report: OSAP5001A - OSAP5001A: Detailed Check Register for

13

Current Time: 17:16:25

Selection:

Vers. 1

OH_DTL.[oh_ck_dt] <= '01/31/2025' AND OH_DTL.[oh_ck_dt] >= '01/01/2025'

Bloomfield Hills Schools
Detailed Check Register for Board Reporting
Check Date From 1/1/2025 TO 1/31/2025

PE ID	Vendor Name	Fund	Object	Check#	Check Date	Invoice #	Description	PO#	Amount	Type
00031986	CENGAGE LEARNING GALE INC	101	55110000	EP 00010603	01/30/2025	85935749	ELD Testbooks for BHHS		565.00	MW
00031986	CENGAGE LEARNING GALE INC	272	55210000	EP 00010603	01/30/2025	86082697	EBooks for all campuses		1,996.73	MW
Vendor Total:									2,561.73	
00000211	CENTRAL MICHIGAN PAPER CO	101	55110000	EP 00010604	01/30/2025	56795400	Paper		1,320.00	MW
Vendor Total:									1,320.00	
00052868	D A CENTRAL INC	101	53190000	EP 00010606	01/30/2025	28085	Engineering Services		680.00	MW
Vendor Total:									680.00	
00058273	DELTA T GROUP DETROIT INC	220	53114000	EP 00010607	01/30/2025	1000027214	Delta T Invoice		653.94	MW
00058273	DELTA T GROUP DETROIT INC	220	53114000	EP 00010607	01/30/2025	1000027156	Delta T Invoice		576.18	MW
Vendor Total:									1,230.12	
00052692	DIRECT ENERGY BUSINESS	272	55520000	EP 00010608	01/30/2025	250150056110979	I.A. 1020 E Sq Lk Rd		2,172.25	MW
00052692	DIRECT ENERGY BUSINESS	101	55520000	EP 00010608	01/30/2025	250150056110979	Fox Hills 1661 Hunters Ridge		0.00	MW
00052692	DIRECT ENERGY BUSINESS	101	55520000	EP 00010608	01/30/2025	250150056110979	Way 765 W Long Lk		1,765.03	MW
00052692	DIRECT ENERGY BUSINESS	101	55520000	EP 00010608	01/30/2025	250150056110979	Eastover 2800 Kensington		3,259.41	MW
00052692	DIRECT ENERGY BUSINESS	101	55520000	EP 00010608	01/30/2025	250150056110979	Conant 4100 Quarton		2,248.70	MW
00052692	DIRECT ENERGY BUSINESS	101	55520000	EP 00010608	01/30/2025	250150056110979	Doyle Center/Booth Center 7273		1,681.09	MW
00052692	DIRECT ENERGY BUSINESS	101	55520000	EP 00010608	01/30/2025	250150056110979	BHHS 4200 Andover		19,506.06	MW
00052692	DIRECT ENERGY BUSINESS	106	55520000	EP 00010608	01/30/2025	250150056110979	Blmn East 1101 Westview		1,347.45	MW
00052692	DIRECT ENERGY BUSINESS	106	55520000	EP 00010608	01/30/2025	250150056110979	Blmn West 3100 Lone Pine		2,013.74	MW
00052692	DIRECT ENERGY BUSINESS	101	55520000	EP 00010608	01/30/2025	250150056110979	Dublin Bldg 4174 Dublin		139.82	MW
00052692	DIRECT ENERGY BUSINESS	101	55520000	EP 00010608	01/30/2025	250150056110979	SHMS 4200 Quarton		4,187.73	MW
00052692	DIRECT ENERGY BUSINESS	101	55520000	EP 00010608	01/30/2025	250150056110979	NHMS 3456 Lahser		5,956.14	MW
00052692	DIRECT ENERGY BUSINESS	101	55520000	EP 00010608	01/30/2025	250150056110979	Lone Pine 2601 Lone Pine		3,813.69	MW
00052692	DIRECT ENERGY BUSINESS	101	55520000	EP 00010608	01/30/2025	250150056110979	Transportation 2780 Kensington		183.85	MW
00052692	DIRECT ENERGY BUSINESS	101	55520000	EP 00010608	01/30/2025	250150056110979	Bowers School House 1219 E Sq		1,564.49	MW
Vendor Total:									49,839.45	
00057083	DRIVERGENT TRANSPORTATION	610	24312268	EP 00010609	01/30/2025	4258	MUNUM Transportation		1,200.00	MW
00057083	DRIVERGENT TRANSPORTATION	610	24312048	EP 00010609	01/30/2025	3608	Service Day Transportation		2,040.00	MW
Vendor Total:									3,240.00	
00058126	EASTOVER ELEMENTARY SCHOOL	610	24317006	EP 00010610	01/30/2025	PTOFINALPAYOUEO	PTO Final Payout		13,996.90	MW
Vendor Total:									13,996.90	
00010094	EDDIE O BASKETBALL CAMPS LLC	230	53190000	EP 00010611	01/30/2025	SER01272025	Advance Rec Winter 2025 Bkb Lg		15,000.00	MW
00010094	EDDIE O BASKETBALL CAMPS LLC	230	55990000	EP 00010611	01/30/2025	REI01212025	Reimburse Eddie O 50% T-Shirts		1,887.38	MW
Vendor Total:									16,887.38	

User: KMOYNIHAN - Kandice Moynihan

Page

Current Date: 02/19/2025

Report: OSAP5001A - OSAP5001A: Detailed Check Register for

14

Current Time: 17:16:25

Selection:

Vers. 1

OH_DTL.[oh_ck_dt] <= '01/31/2025' AND OH_DTL.[oh_ck_dt] >= '01/01/2025'

Bloomfield Hills Schools
Detailed Check Register for Board Reporting
Check Date From 1/1/2025 TO 1/31/2025

PE ID	Vendor Name	Fund	Object	Check#	Check Date	Invoice #	Description	PO#	Amount	Type
00032809	EDUSTAFF LLC	101	53113000	EP 00010612	01/30/2025	20250131011	Contracted Subs 1/12-1/25/25		109,354.62	MW
Vendor Total:									109,354.62	
00054859	ENVIRO-CLEAN SERVICES INC	101	54194000	EP 00010613	01/30/2025	125193	EL Johnson Nature Center		2,482.56	MW
00054859	ENVIRO-CLEAN SERVICES INC	101	54194000	EP 00010613	01/30/2025	125429	Open Gym/Athletics/ACT/TT-BHHS		2,025.96	MW
00054859	ENVIRO-CLEAN SERVICES INC	101	54194000	EP 00010613	01/30/2025	125430	Tamil School-IA		645.04	MW
00054859	ENVIRO-CLEAN SERVICES INC	101	54194000	EP 00010613	01/30/2025	125193	Charles L Bowers Farm		0.00	MW
00054859	ENVIRO-CLEAN SERVICES INC	101	54194000	EP 00010613	01/30/2025	125193	Transportation		1,861.92	MW
00054859	ENVIRO-CLEAN SERVICES INC	101	54194000	EP 00010613	01/30/2025	125193	Bloomin East		7,447.67	MW
00054859	ENVIRO-CLEAN SERVICES INC	101	54194000	EP 00010613	01/30/2025	125193	Bloomin West		7,579.99	MW
00054859	ENVIRO-CLEAN SERVICES INC	101	54194000	EP 00010613	01/30/2025	125193	Bowers Academy		5,229.74	MW
00054859	ENVIRO-CLEAN SERVICES INC	101	54194000	EP 00010613	01/30/2025	125193	High School		66,220.84	MW
00054859	ENVIRO-CLEAN SERVICES INC	101	54194000	EP 00010613	01/30/2025	125193	Addl HS 2nd Shift Person		0.00	MW
00054859	ENVIRO-CLEAN SERVICES INC	101	54194000	EP 00010613	01/30/2025	125193	Lone Pine		20,389.72	MW
00054859	ENVIRO-CLEAN SERVICES INC	101	54194000	EP 00010613	01/30/2025	125193	Addl LP 1st Shift Person		0.00	MW
00054859	ENVIRO-CLEAN SERVICES INC	101	54194000	EP 00010613	01/30/2025	125193	North Hills Middle School		27,572.76	MW
00054859	ENVIRO-CLEAN SERVICES INC	101	54194000	EP 00010613	01/30/2025	125431	Girls Soccer/LAX/FH/OS-NHMS		1,698.90	MW
00054859	ENVIRO-CLEAN SERVICES INC	101	54194000	EP 00010613	01/30/2025	125432	Workouts/Genevieve-SHMS		481.51	MW
00054859	ENVIRO-CLEAN SERVICES INC	101	54194000	EP 00010613	01/30/2025	125193	South Hills Middle School		30,319.94	MW
00054859	ENVIRO-CLEAN SERVICES INC	101	54194000	EP 00010613	01/30/2025	125193	Booth Center/Doyle		5,229.74	MW
00054859	ENVIRO-CLEAN SERVICES INC	101	54194000	EP 00010613	01/30/2025	125193	Conant		15,027.66	MW
00054859	ENVIRO-CLEAN SERVICES INC	101	54194000	EP 00010613	01/30/2025	125193	Eastover Middle School		20,389.72	MW
00054859	ENVIRO-CLEAN SERVICES INC	101	54194000	EP 00010613	01/30/2025	125193	Way		15,027.66	MW
00054859	ENVIRO-CLEAN SERVICES INC	272	54194000	EP 00010613	01/30/2025	125193	International Academy		15,424.60	MW
00054859	ENVIRO-CLEAN SERVICES INC	220	54194000	EP 00010613	01/30/2025	125193	Wing Lake		13,165.74	MW
00054859	ENVIRO-CLEAN SERVICES INC	220	54194000	EP 00010613	01/30/2025	125193	Dublin		310.32	MW
00054859	ENVIRO-CLEAN SERVICES INC	230	54194000	EP 00010613	01/30/2025	125428	ORG at EO		853.99	MW
00054859	ENVIRO-CLEAN SERVICES INC	101	56460000	EP 00010613	01/30/2025	125518	Crdt-Damgd Screen SH- P2400135		-6,250.00	MW
Vendor Total:									253,135.98	
00033905	EXECUTIVE ENERGY SERVICES	101	53190000	EP 00010614	01/30/2025	4825	ENERGY CONSULT SERV DEC 2024		550.00	MW
Vendor Total:									550.00	
00024831	GALLAGHER FIRE EQUIPMENT CO	101	53190000	EP 00010615	01/30/2025	MB76422	NHMS ANSUL FIRE SUPPRESS INSP		200.00	MW
00024831	GALLAGHER FIRE EQUIPMENT CO	101	53190000	EP 00010615	01/30/2025	MB76423	SHMS-ANSUL FIRE SUPPRES		200.00	MW
00024831	GALLAGHER FIRE EQUIPMENT CO	101	53190000	EP 00010615	01/30/2025	MB76424	EO-ANSUL FIRE SUPPRESSION		230.00	MW
00024831	GALLAGHER FIRE EQUIPMENT CO	101	53190000	EP 00010615	01/30/2025	MB76478	BHHS-ANSUL FIRE SUPPR INSPECT		1,700.00	MW

User: KMOYNIHAN - Kandice Moynihan

Page

Current Date: 02/19/2025

Report: OSAP5001A - OSAP5001A: Detailed Check Register for

15

Current Time: 17:16:25

Selection:

Vers. 1

OH_DTL.[oh_ck_dt] <= '01/31/2025' AND OH_DTL.[oh_ck_dt] >= '01/01/2025'

Bloomfield Hills Schools
Detailed Check Register for Board Reporting
Check Date From 1/1/2025 TO 1/31/2025

PE ID	Vendor Name	Fund	Object	Check#	Check Date	Invoice #	Description	PO#	Amount	Type
Vendor Total:									2,330.00	
00003224	GREAT LAKES FURNITURE	250	56450000	EP 00010616	01/30/2025	2934	Using Omnia Contract Pricing N	P2500034	7,204.80	MW
00003224	GREAT LAKES FURNITURE	250	56450000	EP 00010616	01/30/2025	2934	Using Buyboard Contract Pricin	P2500034	6,739.20	MW
00003224	GREAT LAKES FURNITURE	250	56450000	EP 00010616	01/30/2025	2934	INSTALLATION AND SHIPPING	P2500034	2,485.00	MW
Vendor Total:									16,429.00	
00032987	GREATAMERICA LEASING	272	54220000	EP 00010617	01/30/2025	38342872	LEASE PMT# 1919423		2,600.88	MW
00032987	GREATAMERICA LEASING	272	54220000	EP 00010617	01/30/2025	38342872	COLOR COPY COST-ID# 1919423		272.21	MW
00032987	GREATAMERICA LEASING	272	54220000	EP 00010617	01/30/2025	38342872	COLOR COPY COST-ID# 1193123		1,015.82	MW
00032987	GREATAMERICA LEASING	220	54220000	EP 00010617	01/30/2025	38342872	LEASE PMT# 1551039		239.71	MW
00032987	GREATAMERICA LEASING	220	54220000	EP 00010617	01/30/2025	38342872	LEASE PMT# 1551039		239.70	MW
00032987	GREATAMERICA LEASING	101	54220000	EP 00010617	01/30/2025	38342872	LEASE PMT# 1776323		195.30	MW
00032987	GREATAMERICA LEASING	101	54220000	EP 00010617	01/30/2025	38342872	LEASE PMT# 1619752		142.38	MW
00032987	GREATAMERICA LEASING	101	54220000	EP 00010617	01/30/2025	38342872	LEASE PMT# 1705891		237.96	MW
00032987	GREATAMERICA LEASING	101	54220000	EP 00010617	01/30/2025	38342872	COLOR COPY COST-ID# 995883		33.60	MW
00032987	GREATAMERICA LEASING	106	54220000	EP 00010617	01/30/2025	38342872	LEASE PMT# 1590880		200.09	MW
00032987	GREATAMERICA LEASING	106	54220000	EP 00010617	01/30/2025	38342872	COLOR COPY COST-ID# 923862		116.06	MW
00032987	GREATAMERICA LEASING	101	54220000	EP 00010617	01/30/2025	38342872	LEASE PMT# 1705435		522.81	MW
00032987	GREATAMERICA LEASING	101	54220000	EP 00010617	01/30/2025	38342872	COLOR COPY COST-ID# 1017002		224.32	MW
00032987	GREATAMERICA LEASING	101	54220000	EP 00010617	01/30/2025	38342872	COLOR COPY COST-ID# 1017003		97.42	MW
00032987	GREATAMERICA LEASING	101	54220000	EP 00010617	01/30/2025	38342872	LEASE PMT# 1719290		183.89	MW
00032987	GREATAMERICA LEASING	101	54220000	EP 00010617	01/30/2025	38342872	COLOR COPY COST-ID# 1016860		65.41	MW
00032987	GREATAMERICA LEASING	101	54220000	EP 00010617	01/30/2025	38342872	LEASE PMT# 1705435		153.77	MW
00032987	GREATAMERICA LEASING	101	54220000	EP 00010617	01/30/2025	38342872	LEASE PMT# 1952613		171.50	MW
00032987	GREATAMERICA LEASING	101	54220000	EP 00010617	01/30/2025	38342872	COLOR COPY COST-ID# 1267767		86.18	MW
00032987	GREATAMERICA LEASING	101	54220000	EP 00010617	01/30/2025	38342872	LEASE PMT# 1705435		92.26	MW
00032987	GREATAMERICA LEASING	101	54220000	EP 00010617	01/30/2025	38342872	LEASE PMT# 1915178		293.82	MW
00032987	GREATAMERICA LEASING	101	54220000	EP 00010617	01/30/2025	38342872	LEASE PMT# 1950347		353.52	MW
00032987	GREATAMERICA LEASING	101	54220000	EP 00010617	01/30/2025	38342872	COLOR COPY COST-ID# 1221205		271.72	MW
00032987	GREATAMERICA LEASING	101	54220000	EP 00010617	01/30/2025	38342872	LEASE PMT# 1584219		4,862.80	MW
00032987	GREATAMERICA LEASING	101	54220000	EP 00010617	01/30/2025	38342872	LEASE PMT# 1705121		1,060.74	MW
00032987	GREATAMERICA LEASING	101	54220000	EP 00010617	01/30/2025	38342872	LEASE PMT# 1782496		835.43	MW
00032987	GREATAMERICA LEASING	101	54220000	EP 00010617	01/30/2025	38342872	COLOR COPY COST-ID# 925500		455.12	MW
00032987	GREATAMERICA LEASING	101	54220000	EP 00010617	01/30/2025	38342872	COLOR COPY COST-ID# 996507		572.77	MW
00032987	GREATAMERICA LEASING	101	54220000	EP 00010617	01/30/2025	38342872	LEASE PMT# 1950349		197.26	MW

User: KMOYNIHAN - Kandice Moynihan

Page

Current Date: 02/19/2025

Report: OSAP5001A - OSAP5001A: Detailed Check Register for

16

Current Time: 17:16:25

Selection:

Vers. 1

OH_DTL.[oh_ck_dt] <= '01/31/2025' AND OH_DTL.[oh_ck_dt] >= '01/01/2025'

Bloomfield Hills Schools
Detailed Check Register for Board Reporting
Check Date From 1/1/2025 TO 1/31/2025

PE ID	Vendor Name	Fund	Object	Check#	Check Date	Invoice #	Description	PO#	Amount	Type
00032987	GREATAMERICA LEASING	101	54220000	EP 00010617	01/30/2025	38342872	LEASE PMT# 1950346		156.30	MW
00032987	GREATAMERICA LEASING	101	54220000	EP 00010617	01/30/2025	38342872	LEASE PMT# 1903020		2,633.55	MW
00032987	GREATAMERICA LEASING	101	54220000	EP 00010617	01/30/2025	38342872	COLOR COPY COST-ID# 1903020		852.01	MW
00032987	GREATAMERICA LEASING	101	54220000	EP 00010617	01/30/2025	38342872	LEASE PMT# 1795932		2,697.09	MW
00032987	GREATAMERICA LEASING	101	54220000	EP 00010617	01/30/2025	38342872	COLOR COPY COST-ID# 1111547		1,057.49	MW
00032987	GREATAMERICA LEASING	101	54220000	EP 00010617	01/30/2025	38342872	LEASE PMT# 1664236		2,356.65	MW
00032987	GREATAMERICA LEASING	101	54220000	EP 00010617	01/30/2025	38342872	LEASE PMT# 1920479		1,059.42	MW
00032987	GREATAMERICA LEASING	101	54220000	EP 00010617	01/30/2025	38342872	LEASE PMT# 1775066		208.14	MW
00032987	GREATAMERICA LEASING	101	54220000	EP 00010617	01/30/2025	38342872	LEASE PMT# 1777553		193.83	MW
00032987	GREATAMERICA LEASING	101	54220000	EP 00010617	01/30/2025	38342872	LEASE PMT# 1782497		228.25	MW
00032987	GREATAMERICA LEASING	101	54220000	EP 00010617	01/30/2025	38342872	COLOR COPY COST-ID# 1065783		38.64	MW
00032987	GREATAMERICA LEASING	101	54220000	EP 00010617	01/30/2025	38342872	COLOR COPY COST-ID# 1054127		304.84	MW
00032987	GREATAMERICA LEASING	101	54220000	EP 00010617	01/30/2025	38342872	LEASE PMT# 1498271		488.32	MW
00032987	GREATAMERICA LEASING	101	54220000	EP 00010617	01/30/2025	38342872	LEASE PMT# 1664822		1,347.86	MW
00032987	GREATAMERICA LEASING	101	54220000	EP 00010617	01/30/2025	38342872	LEASE PMT# 1711591		968.66	MW
00032987	GREATAMERICA LEASING	101	54220000	EP 00010617	01/30/2025	38342872	COLOR COPY COST-ID# 960282		832.42	MW
00032987	GREATAMERICA LEASING	101	54220000	EP 00010617	01/30/2025	38342872	COLOR COPY COST-ID# 1016861		889.00	MW
00032987	GREATAMERICA LEASING	230	54220000	EP 00010617	01/30/2025	38342872	LEASE PMT# 1711592		246.48	MW
00032987	GREATAMERICA LEASING	230	54220000	EP 00010617	01/30/2025	38342872	COLOR COPY COST-ID# 995898		69.76	MW
Vendor Total:									32,423.16	
00057638	HILLER, TERESA	101	53210000	EP 00010618	01/30/2025	MLGDEC2024	Dec 2024 Mileage Reimb		14.74	MW
Vendor Total:									14.74	
00057910	HOPPER DESIGNS LLC	610	24312066	EP 00010620	01/30/2025	INV2025005	Bogrette - Case		100.00	MW
00057910	HOPPER DESIGNS LLC	610	24312066	EP 00010620	01/30/2025	INV2025005	Bogrette - Labor for chrgr		100.00	MW
00057910	HOPPER DESIGNS LLC	610	24312066	EP 00010620	01/30/2025	INV2025001	Spring Music-Install Microphon		300.00	MW
00057910	HOPPER DESIGNS LLC	610	24312066	EP 00010620	01/30/2025	INV2025001	Spring Music-Microphones		2,500.00	MW
00057910	HOPPER DESIGNS LLC	610	24312066	EP 00010620	01/30/2025	INV2025001	Spring Music-Ear Headst Beige		180.00	MW
00057910	HOPPER DESIGNS LLC	610	24312066	EP 00010620	01/30/2025	INV2025001	Spring Music-Ear Headst Blk		60.00	MW
00057910	HOPPER DESIGNS LLC	610	24312066	EP 00010620	01/30/2025	INV2025005	Bogrette 4 Bay charger		144.00	MW
00057910	HOPPER DESIGNS LLC	610	24317075	EP 00010620	01/30/2025	INV2025005	Bogrette HC Rechrq AA Battery		256.00	MW
Vendor Total:									3,640.00	
00054232	INTERIM OF OAKLAND COUNTY	220	53130000	EP 00010621	01/30/2025	252128	Nursing srvc for DHH student		2,931.50	MW
00054232	INTERIM OF OAKLAND COUNTY	220	53130000	EP 00010621	01/30/2025	252127	Nursing srvc for DHH student		1,834.30	MW
Vendor Total:									4,765.80	

User: KMOYNIHAN - Kandice Moynihan

Page

Current Date: 02/19/2025

Report: OSAP5001A - OSAP5001A: Detailed Check Register for

17

Current Time: 17:16:25

Selection:

Vers. 1

OH_DTL.[oh_ck_dt] <= '01/31/2025' AND OH_DTL.[oh_ck_dt] >= '01/01/2025'

Bloomfield Hills Schools
Detailed Check Register for Board Reporting
Check Date From 1/1/2025 TO 1/31/2025

PE ID	Vendor Name	Fund	Object	Check#	Check Date	Invoice #	Description	PO#	Amount	Type
00034017	INTERIOR ENVIRONMENTS	408	56410000	EP 00010622	01/30/2025	19815	BOND FURNITURE FOR WAY	P2500010	13,517.71	MW
00034017	INTERIOR ENVIRONMENTS	408	56410000	EP 00010622	01/30/2025	19662	BOND FURNITURE FOR LONE PINE	P2500010	14,090.94	MW
00034017	INTERIOR ENVIRONMENTS	408	56410000	EP 00010622	01/30/2025	20041	CONANT FURNITURE BOND 2024P	2400126	19,229.25	MW
Vendor Total:									46,837.90	
00001731	INTL BACCALAUREATE NORTH	610	24313001	EP 00010623	01/30/2025	INV000177798	MERCHANT (IB Exam Fees)		324.00	MW
Vendor Total:									324.00	
00058297	ISSAC, RADHIKA	610	24317001	EP 00010624	01/30/2025	REI11142024	Conference Wk Snack Reimb		145.95	MW
Vendor Total:									145.95	
00052345	KRAMER, JODI	101	53210000	EP 00010625	01/30/2025	MLGDEC2024	December Mileage		9.65	MW
Vendor Total:									9.65	
00053421	LINKEDIN CORP	101	53450000	EP 00010626	01/30/2025	10112566213	LinkedIn Membership		1,850.00	MW
Vendor Total:									1,850.00	
00033682	METRO CONTROLS INC	416	56220000	EP 00010627	01/30/2025	W19276	FARM-HOT WATER TANK		4,304.00	MW
Vendor Total:									4,304.00	
00021565	OAKLAND RHYTHMIC	230	53190000	EP 00010628	01/30/2025	2411DEC24L79	ORG DEC24 L7-9		2,499.00	MW
00021565	OAKLAND RHYTHMIC	230	53190000	EP 00010628	01/30/2025	2411DEC24L79	ORG DEC L7-9		287.00	MW
00021565	OAKLAND RHYTHMIC	230	53190000	EP 00010628	01/30/2025	2411DEC24L79	ORG DEC 24 L7-9		245.00	MW
00021565	OAKLAND RHYTHMIC	230	53190000	EP 00010628	01/30/2025	2411DEC24CLUB	ORG DEC CLUB		1,316.00	MW
00021565	OAKLAND RHYTHMIC	230	53190000	EP 00010628	01/30/2025	2411DEC24L3	ORG DEC24 L3		164.50	MW
00021565	OAKLAND RHYTHMIC	230	53190000	EP 00010628	01/30/2025	2411DEC24L3	ORG DEC L3		1,085.00	MW
00021565	OAKLAND RHYTHMIC	230	53190000	EP 00010628	01/30/2025	2411DEC24L5	ORG DEC L4-5		4,018.00	MW
00021565	OAKLAND RHYTHMIC	230	53190000	EP 00010628	01/30/2025	2411DEC24L6	ORG DEC L6		2,992.50	MW
00021565	OAKLAND RHYTHMIC	230	53190000	EP 00010628	01/30/2025	2411DEC24L79	ORG DEC L7-9		217.00	MW
00021565	OAKLAND RHYTHMIC	230	53190000	EP 00010628	01/30/2025	241324D01	Rhythmic Gymnastics Stars		655.20	MW
00021565	OAKLAND RHYTHMIC	230	53190000	EP 00010628	01/30/2025	241924C02	Rhythmic Gymnastics Stars		907.20	MW
00021565	OAKLAND RHYTHMIC	230	53190000	EP 00010628	01/30/2025	241924C03	Rhythmic Gymnastics		1,075.20	MW
Vendor Total:									15,461.60	
00002667	OAKLAND SCHOOLS	101	55110000	EP 00010629	01/30/2025	A0003101	Books for NTIP		60.38	MW
00002667	OAKLAND SCHOOLS	101	58211000	EP 00010629	01/30/2025	A0003056	VLAC 9-12		36,850.00	MW
00002667	OAKLAND SCHOOLS	101	58211000	EP 00010629	01/30/2025	A0003056	VLAC K-8 (NH)		3,225.00	MW
00002667	OAKLAND SCHOOLS	101	58211000	EP 00010629	01/30/2025	A0003056	VLAC K-8 (SH)		12,900.00	MW
00002667	OAKLAND SCHOOLS	101	58211000	EP 00010629	01/30/2025	A0003056	VLAC K-8 (C)		6,450.00	MW
00002667	OAKLAND SCHOOLS	101	58211000	EP 00010629	01/30/2025	A0003056	VLAC K-8 (LP)		6,450.00	MW
Vendor Total:									65,935.38	

User: KMOYNIHAN - Kandice Moynihan

Page

Current Date: 02/19/2025

Report: OSAP5001A - OSAP5001A: Detailed Check Register for

18

Current Time: 17:16:25

Selection:

Vers. 1

OH_DTL.[oh_ck_dt] <= '01/31/2025' AND OH_DTL.[oh_ck_dt] >= '01/01/2025'

Bloomfield Hills Schools
Detailed Check Register for Board Reporting
Check Date From 1/1/2025 TO 1/31/2025

PE ID	Vendor Name	Fund	Object	Check#	Check Date	Invoice #	Description	PO#	Amount	Type
00057213	P.A.S. CONSULTANTS LLC	124	53190000	EP 00010630	01/30/2025	SER01242025	Director-Public Safety 24/25		4,050.00	MW
Vendor Total:									4,050.00	
00057244	PEOPLE DRIVEN TECHNOLOGY	408	56221000	EP 00010631	01/30/2025	INV16776	Dell Optiplex SFF (7020)		15,900.00	MW
Vendor Total:									15,900.00	
00032094	PLANTE MORAN REALPOINT LLC	408	53198004	EP 00010632	01/30/2025	10377375	OWNERS REP REIMBURSABLE	P2100084	250.81	MW
00032094	PLANTE MORAN REALPOINT LLC	408	53198004	EP 00010632	01/30/2025	10377375	Amendment 1 (179,250) and 2 (2	P2100084	51,000.00	MW
00032094	PLANTE MORAN REALPOINT LLC	408	53198004	EP 00010632	01/30/2025	10377375	Amendment 3 Moving Services an	P2100084	20,000.00	MW
00032094	PLANTE MORAN REALPOINT LLC	408	53198004	EP 00010632	01/30/2025	10377375	Amendment 3 Moving Services an	P2100084	125.13	MW
Vendor Total:									71,375.94	
00052750	PRESIDIO NETWORKED	101	53190000	EP 00010633	01/30/2025	6011825900104	UNITY8-ENT Unity Enterprise ca	P2500062	1,779.47	MW
00052750	PRESIDIO NETWORKED	101	53190000	EP 00010633	01/30/2025	6023425000094	UNITY8-ENT Unity Enterprise ca	P2500062	393.75	MW
Vendor Total:									2,173.22	
00056958	PROPEL TECH & ELECTRIC	101	53190000	EP 00010634	01/30/2025	2492	Data and Communication Wiring		1,500.00	MW
Vendor Total:									1,500.00	
00058114	SEASONAL SUNDRIES	230	55990000	EP 00010635	01/30/2025	SSBF005	CONSIGNMENT - SACHETS		8.40	MW
Vendor Total:									8.40	
00033258	SEATON ATHLETICS LLC	230	53190000	EP 00010636	01/30/2025	210524D04	Seaton Dodgeball		900.00	MW
00033258	SEATON ATHLETICS LLC	230	53190000	EP 00010636	01/30/2025	290024D01	Dragons Floor Hockey		540.00	MW
00033258	SEATON ATHLETICS LLC	230	53190000	EP 00010636	01/30/2025	210524D02	Seaton Dodgeball		1,200.00	MW
00033258	SEATON ATHLETICS LLC	230	53190000	EP 00010636	01/30/2025	290024D02	Other Professional & Tech Serv		600.00	MW
00033258	SEATON ATHLETICS LLC	230	53190000	EP 00010636	01/30/2025	290024D04	Dragons Floor Hockey		660.00	MW
Vendor Total:									3,900.00	
00057902	SMITH, RYAN	101	53210000	EP 00010637	01/30/2025	MLGDEC2024	Dec 2024 Mileage Reimb		12.54	MW
00057902	SMITH, RYAN	101	53210000	EP 00010637	01/30/2025	MLGDEC2024	Dec 2024 Mileage Reimb		12.54	MW
00057902	SMITH, RYAN	101	53210000	EP 00010637	01/30/2025	MLGDEC2024	Dec 2024 Mileage Reimb		9.76	MW
Vendor Total:									34.84	
00018782	SPENCER OIL COMPANY	101	55710000	EP 00010638	01/30/2025	30677859	DIESEL FUEL		12,537.82	MW
Vendor Total:									12,537.82	
00057420	STANDARD INSURANCE	810	53190000	EP 00010639	01/30/2025	0017068300010125	ER Elections Jan 2025		7,464.32	MW
00057420	STANDARD INSURANCE	101	24513371	EP 00010639	01/30/2025	0017068300010125	EE Elections Jan 2025		7,496.10	MW
00057420	STANDARD INSURANCE	101	24513371	EP 00010639	01/30/2025	170683ACC0125	Vol Grp Accident Ins Jan 2025		6,720.20	MW
Vendor Total:									21,680.62	
00054584	SUSAN ADAMS PHOTOGRAPHY	230	53190000	EP 00010640	01/30/2025	202505	Photography Sweetheart Dance		2,500.00	MW

User: KMOYNIHAN - Kandice Moynihan

Page

Current Date: 02/19/2025

Report: OSAP5001A - OSAP5001A: Detailed Check Register for

19

Current Time: 17:16:25

Selection:

Vers. 1

OH_DTL.[oh_ck_dt] <= '01/31/2025' AND OH_DTL.[oh_ck_dt] >= '01/01/2025'

Bloomfield Hills Schools
Detailed Check Register for Board Reporting
Check Date From 1/1/2025 TO 1/31/2025

PE ID	Vendor Name	Fund	Object	Check#	Check Date	Invoice #	Description	PO#	Amount	Type
								Vendor Total:	2,500.00	
00054700	THIRD COAST TECH LLC	101	53190000	EP 00010641	01/30/2025	2369	Wall Mount		2,398.79	MW
00054700	THIRD COAST TECH LLC	101	53190000	EP 00010641	01/30/2025	2369	Wall Mount Labor		590.00	MW
								Vendor Total:	2,988.79	
00057363	TRANE U S INC	101	53190000	EP 00010642	01/30/2025	314985767	BHHS HVAC SERVICE		93.75	MW
								Vendor Total:	93.75	
00057534	UNITED PRODUCTIONS COMPANY	230	53190000	EP 00010643	01/30/2025	2436	DJ/MC Sweetheat Dance		600.00	MW
								Vendor Total:	600.00	
00056703	WORRY FREE TRANSPORTATION	101	53310000	EP 00010644	01/30/2025	35566	TAXIMISCHOOL4DEAF 1/6-10		644.96	MW
								Vendor Total:	644.96	
00058147	MICHIGAN EDUCATION	101	24513315	EP 00010645	01/30/2025	2856/2501030	PAYROLL		578.48	MW
00058147	MICHIGAN EDUCATION	101	24513315	EP 00010645	01/30/2025	2855/2501030	PAYROLL		13,928.09	MW
00058147	MICHIGAN EDUCATION	101	24513315	EP 00010645	01/30/2025	2857/2501030	PAYROLL		221.97	MW
								Vendor Total:	14,728.54	
00005716	ADVANTAGE MEDICAL	220	55110000	AP00525165	01/06/2025	5510	Lift Battery for Room 9		353.65	MW
								Vendor Total:	353.65	
00031016	ARGUS PRESS	610	24312008	AP00525166	01/06/2025	174067	Matz Newspaper Printing		990.00	MW
								Vendor Total:	990.00	
00005831	BLOOMFIELD SPORTS SHOP	610	24312317	AP00525167	01/06/2025	8246	Weghorst (Sweatpants w/ Logo)		250.00	MW
00005831	BLOOMFIELD SPORTS SHOP	610	24312317	AP00525167	01/06/2025	8214	Weghorst (SS TEE)		472.50	MW
								Vendor Total:	722.50	
00024437	COWDREY, KARRI	101	53210000	AP00525168	01/06/2025	MLGDEC2024	DECEMBER 24 MLG		30.15	MW
								Vendor Total:	30.15	
00000992	DETROIT SKATING CLUB	610	24312317	AP00525169	01/06/2025	121	Weghorst (Skating Club)		275.00	MW
00000992	DETROIT SKATING CLUB	610	24312317	AP00525169	01/06/2025	120	Weghorst (Skating Club)		275.00	MW
								Vendor Total:	550.00	
00058288	INFORMED K12	101	53450000	AP00525170	01/06/2025	3457	Annual License 1/2025-6/2025		15,000.00	MW
00058288	INFORMED K12	101	54140000	AP00525170	01/06/2025	3457	Fee for Implementation		7,000.00	MW
								Vendor Total:	22,000.00	
00008370	LAWRENCE TECHNOLOGICAL	101	53710000	AP00525171	01/06/2025	SA0004914A	Fitzgerald (DE) Asmar, Mark		500.00	MW
								Vendor Total:	500.00	
00005745	ROWLEYS WHOLESALE ROWLEY	101	55711000	AP00525172	01/06/2025	147717900	DIESEL EXHAUST FLUID		314.75	MW
								Vendor Total:	314.75	

User: KMOYNIHAN - Kandice Moynihan

Page

Current Date: 02/19/2025

Report: OSAP5001A - OSAP5001A: Detailed Check Register for

20

Current Time: 17:16:25

Selection:

Vers. 1

OH_DTL.[oh_ck_dt] <= '01/31/2025' AND OH_DTL.[oh_ck_dt] >= '01/01/2025'

Bloomfield Hills Schools
Detailed Check Register for Board Reporting
Check Date From 1/1/2025 TO 1/31/2025

PE ID	Vendor Name	Fund	Object	Check#	Check Date	Invoice #	Description	PO#	Amount	Type
00006883	SEIPKE DAME, MEGAN M	220	53210000	AP 00525173	01/06/2025	MLGDEC2024	DECEMBER 24 MLG		77.72	MW
									Vendor Total:	77.72
00055293	TRANSFINDER CORPORATION	101	53141000	AP 00525174	01/06/2025	60093	ONLINE TRAINING FOR OFFICE		900.00	MW
									Vendor Total:	900.00
00021121	VASILE, MARIOARA	101	53225000	AP 00525175	01/06/2025	CONF12072024	Vasile (IB Training, Florida)		377.18	MW
									Vendor Total:	377.18
00056484	CHAPTER 13 STANDING TRUSTEE	101	24513392	AP 00525176	01/06/2025	2850/2501010	24-40534 LSG/WAL		951.00	MW
									Vendor Total:	951.00
00057494	CHAPTER 13 TRUSTEE	101	24513392	AP 00525177	01/06/2025	2850/2501010	21-40461-MAR /WA		288.00	MW
									Vendor Total:	288.00
00055142	313 PRESENTS LLC	101	53199000	AP 00525178	01/16/2025	SER06012025	Mezey (Grad Dep) June 2025		7,500.00	MW
									Vendor Total:	7,500.00
00058268	AINSWORTH, AMELIA	210	53196226	AP 00525179	01/16/2025	GM222608272024	8/27/24 BHHS Swim Timer		25.00	MW
00058268	AINSWORTH, AMELIA	210	53196226	AP 00525179	01/16/2025	GM222609122024	9/12/24 BHHS Swim Timer		25.00	MW
00058268	AINSWORTH, AMELIA	210	53196226	AP 00525179	01/16/2025	GM222609142024	9/14/24 BHHS Swim Timer		25.00	MW
00058268	AINSWORTH, AMELIA	210	53196226	AP 00525179	01/16/2025	GM222609192024	9/19/24 BHHS Swim Timer		25.00	MW
00058268	AINSWORTH, AMELIA	210	53196226	AP 00525179	01/16/2025	GM222610102024	10/10/24 BHHS Swim Timer		25.00	MW
00058268	AINSWORTH, AMELIA	210	53196226	AP 00525179	01/16/2025	GM222611082024	11/8/24 BHHS Swim Timer		25.00	MW
									Vendor Total:	150.00
00033578	AMCOMM	101	53190000	AP 00525180	01/16/2025	434197	Troubleshooting Services		7,694.28	MW
00033578	AMCOMM	430	56410000	AP 00525180	01/16/2025	434206	FOR BHHS AND WING LAKE-	P2300159	2,535.00	MW
									Vendor Total:	10,229.28
00033138	AMERICAN PLUMBING AND	101	54110000	AP 00525181	01/16/2025	59466	BLOOMIN EAST PLUMBING		868.50	MW
									Vendor Total:	868.50
00058035	AMERIGAS PROPANE LP	230	53198011	AP 00525182	01/16/2025	3171916296	PROPANE TANK REFILL		1,630.14	MW
									Vendor Total:	1,630.14
00057528	BASYDLO, ROBERT	101	55110000	AP 00525184	01/16/2025	REI12172024	CC was denied-food for labs		12.92	MW
									Vendor Total:	12.92
00057768	BEHRENS KLAVIER SERVICE LLC	272	54121000	AP 00525185	01/16/2025	103	Piano Pitch Correction Tuning		250.00	MW
									Vendor Total:	250.00
00020231	BLOOMFIELD TOWNSHIP	101	53830000	AP 00525186	01/16/2025	3021320125	SHMS 4200 Quarton Rd		5,088.12	MW
00020231	BLOOMFIELD TOWNSHIP	101	53830000	AP 00525186	01/16/2025	3021330125	Conant ES 4100 Quarton Rd		3,794.13	MW
00020231	BLOOMFIELD TOWNSHIP	101	53830000	AP 00525186	01/16/2025	3024500125	Conant ES 4100 Quarton Rd		552.30	MW

User: KMOYNIHAN - Kandice Moynihan

Page

Current Date: 02/19/2025

Report: OSAP5001A - OSAP5001A: Detailed Check Register for

21

Current Time: 17:16:25

Selection:

Vers. 1

OH_DTL.[oh_ck_dt] <= '01/31/2025' AND OH_DTL.[oh_ck_dt] >= '01/01/2025'

Bloomfield Hills Schools
Detailed Check Register for Board Reporting
Check Date From 1/1/2025 TO 1/31/2025

PE ID	Vendor Name	Fund	Object	Check#	Check Date	Invoice #	Description	PO#	Amount	Type
00020231	BLOOMFIELD TOWNSHIP	101	53830000	AP00525186	01/16/2025	3131480125	Booth 7273 Wing Lk Rd		1,507.15	MW
00020231	BLOOMFIELD TOWNSHIP	101	53830000	AP00525186	01/16/2025	3192480125	Dublin 4174 Dublin Dr		266.63	MW
00020231	BLOOMFIELD TOWNSHIP	101	53830000	AP00525186	01/16/2025	3192960125	BHHS 4200 Andover Rd		270.40	MW
00020231	BLOOMFIELD TOWNSHIP	101	53830000	AP00525186	01/16/2025	3171220125	Wing Lake 6490 Wing Lk Rd		4,819.00	MW
00020231	BLOOMFIELD TOWNSHIP	101	53830000	AP00525186	01/16/2025	3180750125	Nature Center 3355 Franklin Rd		71.32	MW
00020231	BLOOMFIELD TOWNSHIP	101	53830000	AP00525186	01/16/2025	3181730125	Nature Center 3325 Franklin Rd		517.11	MW
00020231	BLOOMFIELD TOWNSHIP	101	53830000	AP00525186	01/16/2025	3182400125	Nature Center 3325 Franklin Rd		1,060.65	MW
00020231	BLOOMFIELD TOWNSHIP	101	53830000	AP00525186	01/16/2025	3191540125	BHHS 4200 Andover		44,514.00	MW
00020231	BLOOMFIELD TOWNSHIP	101	53830000	AP00525186	01/16/2025	3191800125	BHHS 4220 Andover Rd		589.66	MW
Vendor Total:									63,050.47	
00000438	BLOOMFIELD YOUTH ASSISTANCE	610	24317006	AP00525187	01/16/2025	EXP12202024	DONATION FROM LONE PINE		1,194.25	MW
Vendor Total:									1,194.25	
00058291	BLUMENTHAL, MARISSA	210	57410000	AP00525188	01/16/2025	REI12192024	Reimburse NISCA Membership		225.00	MW
Vendor Total:									225.00	
00031571	BRENDELS SEPTIC TANK SERVICE	230	53190000	AP00525189	01/16/2025	246049	PORTABLE RESTROOM FOR		95.00	MW
00031571	BRENDELS SEPTIC TANK SERVICE	230	54220000	AP00525189	01/16/2025	246049	PORTABLE RESTROOM FOR		95.00	MW
Vendor Total:									190.00	
00003590	BSN SPORTS INC	610	24317024	AP00525190	01/16/2025	928294639	Hartley (Beanie)		648.00	MW
Vendor Total:									648.00	
00057400	BURKS, MELANIE	220	53210000	AP00525191	01/16/2025	MLGDEC2024	DECEMBER 24 MLG		181.50	MW
Vendor Total:									181.50	
00000429	CHARTER TOWNSHIP OF	101	55711000	AP00525192	01/16/2025	202500003009	Unleaded Fuel		785.84	MW
00000429	CHARTER TOWNSHIP OF	101	55711000	AP00525192	01/16/2025	202500003009	Diesel Fuel		138.88	MW
Vendor Total:									924.72	
00057822	CHIN, EVELYN	210	53196205	AP00525193	01/16/2025	GM220512112024	12/11/24 NHMS Bkb Scorer		50.00	MW
Vendor Total:									50.00	
00057563	CMC NEPTUNE LLC	210	53450000	AP00525194	01/16/2025	19246	Music at BHHS 7/15/25-7/14/26		1,620.00	MW
Vendor Total:									1,620.00	
00055208	CORNACCHIONE, NICOLE	101	55990000	AP00525195	01/16/2025	REI12212024	THERAPY DOG DAISY GROOMING		60.00	MW
Vendor Total:									60.00	
00007617	D'AIGLE, TREVOR	101	57410000	AP00525196	01/16/2025	REI01032025	CDL RENEWAL		79.77	MW
Vendor Total:									79.77	
00055694	DELUCA, LINDSEY	101	53450000	AP00525197	01/16/2025	REI01072025	DeLuca Gimkit Yrly Subscript		59.88	MW

Bloomfield Hills Schools

Detailed Check Register for Board Reporting

Check Date From 1/1/2025 TO 1/31/2025

PE ID	Vendor Name	Fund	Object	Check#	Check Date	Invoice #	Description	PO#	Amount	Type
									Vendor Total:	59.88
00058141	DURAK, KATHLEEN	230	55990000	AP00525198	01/16/2025	REI01072025	WINTER PARK SUPPLIES		58.59	MW
00058141	DURAK, KATHLEEN	230	55990000	AP00525198	01/16/2025	REI01042025	WINTER PARK SUPPLIES		133.47	MW
									Vendor Total:	192.06
00003809	ENVIRONMENTAL NETWORK INC	101	55110000	AP00525199	01/16/2025	243937	Beauchamp (Waste Disposal)		3,221.77	MW
00003809	ENVIRONMENTAL NETWORK INC	101	55110000	AP00525199	01/16/2025	243937	Ryfiak (Waste Disposal)		3,221.78	MW
									Vendor Total:	6,443.55
00058300	FOWLerville COMMUNITY	210	57418222	AP00525200	01/16/2025	V222201102025	1/10/25 BHHS G Wrestling Invite		30.00	MW
									Vendor Total:	30.00
00053435	FRASER PUBLIC SCHOOLS	210	57418395	AP00525201	01/16/2025	V639501112025	1/11/25 BHHS Gymnastics Invite		200.00	MW
									Vendor Total:	200.00
00055138	GARDEN CITY PUBLIC SCHOOLS	210	57418222	AP00525202	01/16/2025	JV222201112025	1/11/25 BHHS JV Wrest Invite		225.00	MW
									Vendor Total:	225.00
00033644	GREAT LAKES POWER AND	416	56220000	AP00525203	01/16/2025	25004	SHMS LIGHTING-IT CLOSET		2,800.00	MW
									Vendor Total:	2,800.00
00057820	HEISEY, EMMA	220	53210000	AP00525204	01/16/2025	MLGDEC2024	DECEMBER 24 MLG		5.36	MW
									Vendor Total:	5.36
00058293	KAVANAUGH, LOUISE	230	55990000	AP00525205	01/16/2025	REI10242024	EMBROIDERY FOR HORSE VESTS		153.00	MW
									Vendor Total:	153.00
00057790	KING, CAROLINE	210	53196205	AP00525206	01/16/2025	GM220512112024	12/11/24 NHMS Bkb Scorer		50.00	MW
									Vendor Total:	50.00
00052242	LANGWELL, STEPHANIE	610	24317006	AP00525207	01/16/2025	REI12072024	Langwell, S (Holiday Sticker)		50.00	MW
									Vendor Total:	50.00
00057818	LAPLANTE, KRISTEN	101	53330000	AP00525208	01/16/2025	MLGDEC2024	DECEMBER 24 MLG		1,189.92	MW
									Vendor Total:	1,189.92
00023050	MERCHANT, AMY	101	53220000	AP00525209	01/16/2025	MLGDEC2024	Merchant (Travel)		39.40	MW
00023050	MERCHANT, AMY	101	53220000	AP00525209	01/16/2025	MLGNOV2024	Merchant (Travel)		38.59	MW
									Vendor Total:	77.99
00055235	N FARMINGTON BOYS GOLF LLC	210	57418212	AP00525210	01/16/2025	JVA221205152025	5/15/25 JVA G Golf Invite		205.00	MW
00055235	N FARMINGTON BOYS GOLF LLC	210	57418212	AP00525210	01/16/2025	JVB221205152025	5/15/25 BHHS JVB G Golf Invite		205.00	MW
									Vendor Total:	410.00
00006971	NOVAK, JENNIFER L	101	55110000	AP00525211	01/16/2025	REI12192024	Novak Science Biology Supplies		66.71	MW
									Vendor Total:	66.71

User: KMOYNIHAN - Kandice Moynihan

Page

Current Date: 02/19/2025

Report: OSAP5001A - OSAP5001A: Detailed Check Register for

23

Current Time: 17:16:25

Selection:

Vers. 1

OH_DTL.[oh_ck_dt] <= '01/31/2025' AND OH_DTL.[oh_ck_dt] >= '01/01/2025'

Bloomfield Hills Schools
Detailed Check Register for Board Reporting
Check Date From 1/1/2025 TO 1/31/2025

PE ID	Vendor Name	Fund	Object	Check#	Check Date	Invoice #	Description	PO#	Amount	Type
00002658	OAKLAND COUNTY TREASURER	101	53430000	AP00525212	01/16/2025	CI051078	Metered Postage 11/16-12/15/24		198.74	MW
Vendor Total:									198.74	
00002658	OAKLAND COUNTY TREASURER	101	41190000	AP00525213	01/16/2025	2004012312024	Genrl Fund Oakland Co Tax Dec		20,129.63	MW
00002658	OAKLAND COUNTY TREASURER	416	41190000	AP00525213	01/16/2025	2004012312024	Sinking Fd Oakland Co Tax Dec		80.73	MW
00002658	OAKLAND COUNTY TREASURER	310	41190000	AP00525213	01/16/2025	2004012312024	Debt Fund Oakland Co Tax Dec		318.91	MW
Vendor Total:									20,529.27	
00058290	PARKS SHOW CATTLE LLC	101	55990000	AP00525214	01/16/2025	10000	ANIMAL FEED		6,082.75	MW
00058290	PARKS SHOW CATTLE LLC	101	55110000	AP00525214	01/16/2025	10001	COB CORN - HARVEST		432.00	MW
Vendor Total:									6,514.75	
00019525	PFROMM, JANE	220	53210000	AP00525215	01/16/2025	MLGDEC2024	DECEMBER 24 MLG		62.85	MW
Vendor Total:									62.85	
00019685	SCHOOL HEALTH CORPORATION	210	55993000	AP00525216	01/16/2025	CINV000171816	Mat Cleaner Spray		213.96	MW
Vendor Total:									213.96	
00052784	SIGNING PROS LLC	220	53190000	AP00525217	01/16/2025	19337	Interpreting services		138.54	MW
Vendor Total:									138.54	
00058296	SPENCER, DALE	101	57410000	AP00525218	01/16/2025	REI12262024	CDL RENEWAL SPENCER		70.00	MW
Vendor Total:									70.00	
00056539	SPRINGBOARDS AND MORE	210	55990226	AP00525219	01/16/2025	20958	Duraflex 16' Diving Board		6,689.30	MW
Vendor Total:									6,689.30	
00058304	TSADIK, SAMRY	106	41810150	AP00525220	01/16/2025	REF01062025	REFUND 1ST/2ND PS		1,794.00	MW
Vendor Total:									1,794.00	
00057518	TURNITIN LLC	272	53450000	AP00525221	01/16/2025	INTII53568	TURNITIN TRI-CAMPUS		5,731.00	MW
Vendor Total:									5,731.00	
00018699	UNDERGROUND PRINTING	610	24317024	AP00525222	01/16/2025	1015076	Hartley (Misc..Hats)		1,796.16	MW
00018699	UNDERGROUND PRINTING	610	24317024	AP00525222	01/16/2025	1015077	Hartley (Headband)		486.72	MW
00018699	UNDERGROUND PRINTING	610	24317024	AP00525222	01/16/2025	1016371	Hartley (Teddy Bear)		685.50	MW
00018699	UNDERGROUND PRINTING	610	24317024	AP00525222	01/16/2025	1016364	Hartley (Crossbody Pack)		906.24	MW
00018699	UNDERGROUND PRINTING	610	24317024	AP00525222	01/16/2025	1016372	Hartley (Card Sleeve)		402.50	MW
00018699	UNDERGROUND PRINTING	610	24317024	AP00525222	01/16/2025	1018469	Hartley (Sweatshirts)		1,960.72	MW
00018699	UNDERGROUND PRINTING	610	24317024	AP00525222	01/16/2025	1016373	Hartley (Speakers)		623.50	MW
Vendor Total:									6,861.34	
00011391	WAYNE COUNTY RESA	101	55113000	AP00525223	01/16/2025	107143	TRIP MANAGER USAGE 2024-25		3,816.00	MW
Vendor Total:									3,816.00	

Bloomfield Hills Schools
Detailed Check Register for Board Reporting
Check Date From 1/1/2025 TO 1/31/2025

PE ID	Vendor Name	Fund	Object	Check#	Check Date	Invoice #	Description	PO#	Amount	Type
00055668	ZOCCOLI, LENA	101	53210000	AP 00525224	01/16/2025	MLGDEC2024	DECEMBER 24 MLG		24.12	MW
Vendor Total:									24.12	
00033146	BLOOMFIELD HILLS ROTARY	101	57410000	AP 00525225	01/16/2025	EXP01012025	ROTARY CLUB MEMBERSHIP		164.00	MW
00033146	BLOOMFIELD HILLS ROTARY	101	57410000	AP 00525225	01/16/2025	EXP01012025	ROTARY CLUB MEMBERSHIP		164.00	MW
Vendor Total:									328.00	
00056484	CHAPTER 13 STANDING TRUSTEE	101	24513392	AP 00525226	01/16/2025	2850/2501020	24-40534 LSG/WAL		951.00	MW
Vendor Total:									951.00	
00057494	CHAPTER 13 TRUSTEE	101	24513392	AP 00525227	01/16/2025	2850/2501020	21-40461-MAR /WA		288.00	MW
Vendor Total:									288.00	
00058149	MICHIGAN ORGANIZING	101	24513315	AP 00525228	01/16/2025	2859/2501020	PAYROLL		879.45	MW
Vendor Total:									879.45	
00058309	ANTONE, WILLIAM	210	53196226	AP 00525229	01/30/2025	GM222611082024	11/8/24 BHHS Swim Timer		25.00	MW
Vendor Total:									25.00	
00000341	BARRYS LETS RENT IT LTD	230	53190000	AP 00525230	01/30/2025	58337	Coat Racks for Sweetheart Danc		491.00	MW
Vendor Total:									491.00	
00055675	BIG DADDY BODY ART	610	24317006	AP 00525231	01/30/2025	SER06062025	LP CARNIVAL BOOKING FEE		256.00	MW
Vendor Total:									256.00	
00054994	BRIGHTON AREA SCHOOLS	210	57418222	AP 00525232	01/30/2025	V222212132024	BHHS G Wrest Invite 12/13/24		50.00	MW
Vendor Total:									50.00	
00003590	BSN SPORTS INC	610	24317024	AP 00525233	01/30/2025	928448306	Hartley (Shirts)		336.00	MW
Vendor Total:									336.00	
00032394	CHESS WIZARDS INCORPORATED	230	53190000	AP 00525234	01/30/2025	227224D01	Chess Wizards		1,152.00	MW
00032394	CHESS WIZARDS INCORPORATED	230	53190000	AP 00525234	01/30/2025	227224D03	Chess Wizards - Way		1,792.00	MW
Vendor Total:									2,944.00	
00057822	CHIN, EVELYN	210	53196205	AP 00525235	01/30/2025	GM220501082025	1/8/25 NHMS Bkb Scorer		50.00	MW
00057822	CHIN, EVELYN	210	53196205	AP 00525235	01/30/2025	GM220501092025	1/9/25 NHMS 7th Bkb Scorer		25.00	MW
Vendor Total:									75.00	
00057532	COLDWATER COMMUNITY	210	57410000	AP 00525236	01/30/2025	V639502082025	2/8/25 BHHS Gymnastics Invite		175.00	MW
Vendor Total:									175.00	
00057492	DUBIE, ASHLEIGH	610	24312268	AP 00525237	01/30/2025	CONF01192025	Meal Reimbursement		196.40	MW
Vendor Total:									196.40	
00057486	GREENBLATT, JOEL	610	24312268	AP 00525238	01/30/2025	CONF01192025	MUN Conf Meal Reimbursement		232.69	MW
Vendor Total:									232.69	

User: KMOYNIHAN - Kandice Moynihan

Page

Current Date: 02/19/2025

Report: OSAP5001A - OSAP5001A: Detailed Check Register for

25

Current Time: 17:16:25

Selection:

Vers. 1

OH_DTL.[oh_ck_dt] <= '01/31/2025' AND OH_DTL.[oh_ck_dt] >= '01/01/2025'

Bloomfield Hills Schools
Detailed Check Register for Board Reporting
Check Date From 1/1/2025 TO 1/31/2025

PE ID	Vendor Name	Fund	Object	Check#	Check Date	Invoice #	Description	PO#	Amount	Type
00057790	KING, CAROLINE	210	53196205	AP00525239	01/30/2025	GM220501082025	1/8/25 NHMS Bkb Scorer		50.00	MW
00057790	KING, CAROLINE	210	53196205	AP00525239	01/30/2025	GM220501092025	1/9/25 NHMS Bkb Scorer		50.00	MW
00057790	KING, CAROLINE	210	53196205	AP00525239	01/30/2025	GM220501132025	1/13/25 NHMS Bkb Scorer		50.00	MW
Vendor Total:									150.00	
00058307	MACHSHCA	210	57418225	AP00525240	01/30/2025	V222501202025	1/20/25 BHHS V B Hky Invite		450.00	MW
Vendor Total:									450.00	
00058207	MALASKY, STACEY	230	55990000	AP00525241	01/30/2025	000063	CONSIGNMENT - TEA TOWELS		93.60	MW
Vendor Total:									93.60	
00021391	METRO ATHLETIC OFFICIALS	210	53193205	AP00525242	01/30/2025	SER01022025	NH Bkb Official Assgn W 24/25		237.50	MW
00021391	METRO ATHLETIC OFFICIALS	210	53193205	AP00525242	01/30/2025	SER01022025	SH Bkb Official Assgn W 24/25		237.50	MW
00021391	METRO ATHLETIC OFFICIALS	210	53193210	AP00525242	01/30/2025	SER01022025	NH FB Official Assgn Fall 24		237.50	MW
00021391	METRO ATHLETIC OFFICIALS	210	53193210	AP00525242	01/30/2025	SER01022025	SH FB Official Assgn Fall 24		237.50	MW
Vendor Total:									950.00	
00007966	MICHIGAN INTERSCHOLASTIC	610	24317075	AP00525243	01/30/2025	2025185	Bogrette (Theatre Reg. Comp)		350.00	MW
Vendor Total:									350.00	
00007966	MICHIGAN INTERSCHOLASTIC	211	57410000	AP00525244	01/30/2025	2025218	BHHS ML Invitational 12/7/24		275.00	MW
Vendor Total:									275.00	
00033713	NOVI HIGH SCHOOL	210	57418221	AP00525245	01/30/2025	9222109072024	9/7/24 BHHS 9th VB Invite		225.00	MW
00033713	NOVI HIGH SCHOOL	210	57418221	AP00525245	01/30/2025	JV222109052024	9/5/24 BHHS JV VB Invite		175.00	MW
00033713	NOVI HIGH SCHOOL	210	57418221	AP00525245	01/30/2025	V222111022024	11/2/24 BHHS V VB Invite		225.00	MW
Vendor Total:									625.00	
00013056	OAKLAND ACTIVITIES	610	24317097	AP00525246	01/30/2025	MEMBOAAFY25IAOAA	Affiliate Dues 24/25 SY		1,100.00	MW
Vendor Total:									1,100.00	
00020959	OAKLAND COMMUNITY COLLEGE	101	53710000	AP00525247	01/30/2025	0000013134	Alsayedsuliman 2025 WINTER OCC		878.25	MW
00020959	OAKLAND COMMUNITY COLLEGE	101	53710000	AP00525247	01/30/2025	0000013135	Basha, N 2025 WINTER OCC		835.50	MW
00020959	OAKLAND COMMUNITY COLLEGE	101	53710000	AP00525247	01/30/2025	0000011506	21 WINTER Wilson, J Balance Ow		304.82	MW
Vendor Total:									2,018.57	
00007298	PETERSON, KENDRA R	101	53210000	AP00525248	01/30/2025	MLGNOV2024	Nov 2024 Mileage Reimb		7.17	MW
00007298	PETERSON, KENDRA R	101	53210000	AP00525248	01/30/2025	MLGNOV2024	Nov 2024 Mileage Reimb		7.17	MW
00007298	PETERSON, KENDRA R	101	53210000	AP00525248	01/30/2025	MLGNOV2024	Nov 2024 Mileage Reimb		7.17	MW
Vendor Total:									21.51	
00005745	ROWLEYS WHOLESALE ROWLEY	101	55711000	AP00525249	01/30/2025	237170200	DIESEL EXHAUST FLUID		325.67	MW
00005745	ROWLEYS WHOLESALE ROWLEY	101	55711000	AP00525249	01/30/2025	237170400	BRAKE CLEANER		96.48	MW

User: KMOYNIHAN - Kandice Moynihan

Page

Current Date: 02/19/2025

Report: OSAP5001A - OSAP5001A: Detailed Check Register for

26

Current Time: 17:16:25

Selection:

Vers. 1

OH_DTL.[oh_ck_dt] <= '01/31/2025' AND OH_DTL.[oh_ck_dt] >= '01/01/2025'

Bloomfield Hills Schools
Detailed Check Register for Board Reporting
Check Date From 1/1/2025 TO 1/31/2025

PE ID	Vendor Name	Fund	Object	Check#	Check Date	Invoice #	Description	PO#	Amount	Type
									Vendor Total:	422.15
00019685	SCHOOL HEALTH CORPORATION	210	55993000	AP00525250	01/30/2025	CINV000153524	Theraband Loop 12" Green		25.04	MW
00019685	SCHOOL HEALTH CORPORATION	210	55993000	AP00525250	01/30/2025	CINV000154748	Theraband Loop 12" Green		37.56	MW
00019685	SCHOOL HEALTH CORPORATION	210	55993000	AP00525250	01/30/2025	CINV000173884	Theraband Loop 12" Blue		32.20	MW
									Vendor Total:	94.80
00058303	THOMAS, RUFUS	101	57410000	AP00525251	01/30/2025	REI01142025	CDL ENDORCEMENT		35.00	MW
									Vendor Total:	35.00
00057041	TOWN & COUNTRY POOLS INC	101	55990000	AP00525252	01/30/2025	64546	NHMS POOL CHEMICALS		433.50	MW
00057041	TOWN & COUNTRY POOLS INC	101	55990000	AP00525252	01/30/2025	64621	NHMS POOL CHEMICALS		577.50	MW
									Vendor Total:	1,011.00
00054940	TRIUMPH CHARTER LLC	211	53190000	AP00525253	01/30/2025	9973	Zoz C (Forensics) Trip 13905		1,300.00	MW
									Vendor Total:	1,300.00
00057792	WILLIAMS, JANAVIA	101	55990000	AP00525254	01/30/2025	PCDEC2024	12/2-12/20/24 Petty Cash Reimb		327.73	MW
									Vendor Total:	327.73
00058305	YALE PUBLIC SCHOOL DISTRICT	210	57418222	AP00525255	01/30/2025	JV222212142024	12/14/24 BHHS JV Wrest Invite		200.00	MW
									Vendor Total:	200.00
00058302	YI, GABRIELA	210	53196205	AP00525256	01/30/2025	GM220501092025	1/9/25 NHMS Bkb Scorer		50.00	MW
									Vendor Total:	50.00
00057887	ZACHARIAH, SONAL	210	53196205	AP00525257	01/30/2025	GM220501102025	1/10/25 BHHS Bkb Scorer		40.00	MW
									Vendor Total:	40.00
00058214	ZIFF, BROOKE	210	53196205	AP00525258	01/30/2025	GM220501082025	1/8/25 NHMS Bkb Scorer		50.00	MW
									Vendor Total:	50.00
00057035	SPECTRUM ENTERTAINMENT	610	24312412	AP00525259	01/30/2025	SER02082025	KLaliberte (Dance/Photobooth)		900.00	MW
									Vendor Total:	900.00
00056484	CHAPTER 13 STANDING TRUSTEE	101	24513392	AP00525260	01/30/2025	2850/2501030	24-40534 LSG/WAL		951.00	MW
									Vendor Total:	951.00
00057494	CHAPTER 13 TRUSTEE	101	24513392	AP00525261	01/30/2025	2850/2501030	21-40461-MAR /WA		288.00	MW
									Vendor Total:	288.00
Total # of Checks:					245				Grand Total:	3,626,723.24

End of Report

User: KMOYNIHAN - Kandice Moynihan

Page

Current Date: 02/19/2025

Report: OSAP5001A - OSAP5001A: Detailed Check Register for

27

Current Time: 17:16:25

Selection:

Vers. 1

OH_DTL.[oh_ck_dt] <= '01/31/2025' AND OH_DTL.[oh_ck_dt] >= '01/01/2025'



Bloomfield Hills Board of Education

Memo

To: Superintendent and Board of Education
From: Kandice Moynihan, Assistant Superintendent of Business Services
Date: February 24, 2025
Re: Request to Approve Monthly Financial Report

Recommended Motion:

I move the Board of Education to approve the monthly financial report, as presented.

Background Information:

ATTACHMENTS:

File Name	Description
□ January_2025_Budget_to_Actual_Report.pdf	January 2025 Budget to Actual Report

Bloomfield Hills Schools - General Fund
Statement of Revenues and Expenditures
For the Period July 1, 2024 - January 31, 2025 (unaudited)

Revenue	Approved Budget 12/16/24	Actual	Percent of Budget
Local Sources	41,278,127	20,266,613	49.10%
State Sources	56,332,418	20,422,887	36.25%
Federal Sources	2,675,108	18,778	0.70%
Interdistrict Sources	8,482,939	3,858,600	45.49%
Transfers In	70,000	-	0.00%
Total revenue	\$ 108,838,592	\$ 44,566,878	40.95%
 Expenditures			
Instruction:			
Basic Programs	46,602,408	22,310,901	47.87%
Added Needs	15,301,884	7,333,822	47.93%
Total instruction	61,904,292	29,644,723	47.89%
Support Services:			
Pupil	9,294,440	4,627,493	49.79%
Instructional Services	7,407,305	3,617,919	48.84%
General Administration	1,202,722	710,635	59.09%
School Administration	4,600,227	2,464,577	53.58%
Business Services	1,255,050	608,482	48.48%
Maintenance and Operations	9,522,382	4,425,946	46.48%
Transportation	4,175,288	2,073,913	49.67%
Central Services	4,556,989	3,351,138	73.54%
Cocurricular Activities (Athletics)	2,432,962	1,063,909	43.73%
Total support services	44,447,365	22,944,012	51.62%
Community Services	2,028,689	1,131,870	55.79%
Debt Service	181,804	-	0.00%
Total expenditures	\$ 108,562,150	\$ 53,720,605	49.48%
 Net Change in Fund Balance	 \$ 276,442	 \$ (9,153,727)	



Bloomfield Hills Board of Education

Memo

To: Superintendent and Board of Education
From: Jacob McDermott, Director of Maintenance and Operations
Date: February 24, 2025
Re: Request to Approve Purchase of Replacement Vehicles for Maintenance & Operations

Recommended Motion:

I move the Board of Education to approve the purchase of one (1) 2025 GMC Sierra 3500HD, and (1) 2024 GMC Savana 3500 for Maintenance and Operations in the total amount of \$103,508 to Todd Wenzel Buick GMC to be paid from the General Fund, as presented.

Background Information:

Maintenance and Operations is requesting to purchase of two vehicles from Todd Wenzel and part of MI Deal, as follows:

- Plow truck, 2024 GMC Sierra 3500 HD with plow- \$56,845. This is to replace a rusting out 2016 GMC 3/4 ton Sierra.
- HVAC van, 2024 GMC Savana 3500 with shelving \$46,663. This is to replace our 2012 HVAC van.

Both vehicles support the work of the Maintenance & Operations department, and the total request of General Fund dollars is \$103,508.

ATTACHMENTS:

File Name	Description
☐ 2024_GMC_Sierra_3500HD_Reg_Cab_4x4.pdf	GMC Sierra
☐ 2024_GMC_Savana_3500_Ext_Cargo_Van.pdf	GMC Savana



Todd Wenzel Buick GMC and TW Chevrolet

Albert Li | (734) 713-1065 | ali@toddwenzel.com

Bloomfield Hills Schools

Prepared For: Jacob McDermott

(248) 420-7504

jmcdermott@bloomfield.org

[Fleet] 2024 GMC Sierra 3500HD (TK30903) 4WD Reg Cab 142" Pro (12)

TODD WENZEL BUICK GMC of WESTLAND

35100 FORD RD

WESTLAND, MI 48185

State of Michigan MiDeal Contract # MA240000001205

MiDeal Spec # 0078-4WDL

Bloomfield Hills Schools Pricing

(MiDeal Pricing)

2024 GMC Sierra 3500HD Reg Cab 4x4 Pro w/ 8' Bed

11300# GVWR 6.6L Gas V8 / Allison 10-Spd Reg Cab w/ 8' Bed

Spec 0078 - 2024 GMC Sierra 3500HD Reg Cab 4wd \$ 45,796.00

W8V - Western 8'6" MVP3 Steel V-Plow w/ Deflector \$ 8,170.00

SBL - Spray-On Bedliner (UTR, RhinoLining) \$ 629.00

DEL - Delivery per MiDeal (Bloomfield Hills, MI) \$ 64.00

Total \$ 54,659.00

Options:

MLP - Muni LED G/A Lighting Pkg (4-Way, MLB) + \$ 2,186.00

WMA - Western Marauder Poly V-Box Spreader + \$ 8,314.00

WSC - Western Spreader Camera Kit + \$ 325.00

Prices Quoted are for a 2024MY MiDeal GM Dealer Stock Unit.

This Unit is Available for Immediate Upfitting; Subject to Prior Sale.

FOB Bloomfield Hills, MI

REPLACES
2016 SIERRA
#166 3/4 PN
PASTORALIST



Todd Wenzel Buick GMC and TW Chevrolet

Albert Li | (734) 713-1065 | ali@toddwenzel.com

[Fleet] 2024 GMC Sierra 3500HD (TK30903) 4WD Reg Cab 142" Pro (12) (✔ Complete)

Price Summary

PRICE SUMMARY	
	MSRP
Base Price	\$49,400.00
Total Options	\$840.00
Vehicle Subtotal	\$50,240.00
Destination Charge	\$1,995.00
Grand Total	\$52,235.00

This document contains information considered Confidential between GM and its Clients uniquely. The information provided is not intended for public disclosure. Prices, specifications, and availability are subject to change without notice, and do not include certain fees, taxes and charges that may be required by law or vary by manufacturer or region. Performance figures are guidelines only, and actual performance may vary. Photos may not represent actual vehicles or exact configurations. Content based on report preparer's input is subject to the accuracy of the input provided.

Data Version: 24619, Data Updated: Feb 2, 2025 6:43:00 PM PST.



Todd Wenzel Buick GMC and TW Chevrolet

Albert Li | (734) 713-1065 | ali@toddwenzel.com

[Fleet] 2024 GMC Sierra 3500HD (TK30903) 4WD Reg Cab 142" Pro (12) (✔ Complete)

Selected Model and Options

MODEL

CODE	MODEL
TK30903	2024 GMC Sierra 3500HD 4WD Reg Cab 142" Pro

COLORS

CODE	DESCRIPTION
GAZ	Summit White

OPTIONS

CODE	DESCRIPTION
E63	Pickup bed
SRW	Single Rear Wheels
FE9	Emissions, Federal requirements
L8T	Engine, 6.6L V8 with Direct Injection and Variable Valve Timing, gasoline
MKM	Transmission, Allison 10-Speed automatic
JFP	GVWR, 11,300 lbs. (5126 kg) with single rear wheels
GT4	Rear axle, 3.73 ratio
1SA	Pro Preferred Equipment Group
PYT	Wheels, 18" (45.7 cm) 8-spoke painted steel, Silver Extended
QF6	Tires, LT275/70R18E all-terrain, blackwall
ZYG	Tire, spare LT275/70R18 all-terrain, blackwall
GAZ	Summit White
AZ3	Seats, front 40/20/40 split-bench
H1T	Jet Black, Cloth seat trim
IOR	Audio system, GMC Infotainment System with 7" diagonal color touchscreen, AM/FM stereo
VYU	Snow Plow Prep/Camper Package
K4Z	Battery, auxiliary, 700 cold-cranking amps/70 Amp-hr
KW5	Alternator, 220 amps
JL1	Trailer brake controller, integrated
NZZ	Skid Plates
U01	Lamps, Smoked Amber roof marker, (LED)

This document contains information considered Confidential between GM and its Clients uniquely. The information provided is not intended for public disclosure. Prices, specifications, and availability are subject to change without notice, and do not include certain fees, taxes and charges that may be required by law or vary by manufacturer or region. Performance figures are guidelines only, and actual performance may vary. Photos may not represent actual vehicles or exact configurations. Content based on report preparer's input is subject to the accuracy of the input provided.

Data Version: 24619. Data Updated: Feb 2, 2025 6:43:00 PM PST.



Todd Wenzel Buick GMC and TW Chevrolet

Albert Li | (734) 713-1065 | ali@toddwenzel.com

[Fleet] 2024 GMC Sierra 3500HD (TK30903) 4WD Reg Cab 142" Pro (12) (✔ Complete)

OPTIONS

CODE	DESCRIPTION
K34	Cruise control, steering wheel-mounted
9L7	Upfitter switch kit, (5)
R9L	Deleted 3 Years of OnStar Remote Access
Options Total	

This document contains information considered Confidential between GM and its Clients uniquely. The information provided is not intended for public disclosure. Prices, specifications, and availability are subject to change without notice, and do not include certain fees, taxes and charges that may be required by law or vary by manufacturer or region. Performance figures are guidelines only, and actual performance may vary. Photos may not represent actual vehicles or exact configurations. Content based on report preparer's input is subject to the accuracy of the input provided.

Data Version: 24619. Data Updated: Feb 2, 2025 6:43:00 PM PST.



Todd Wenzel Buick GMC and TW Chevrolet

Albert Li | (734) 713-1065 | ali@toddwenzel.com

[Fleet] 2024 GMC Sierra 3500HD (TK30903) 4WD Reg Cab 142" Pro (12) (✔ Complete)

Standard Equipment

Package

Sierra HD Pro Safety includes (UEU) Forward Collision Alert, (UE4) Following Distance Indicator, (UKJ) Front Pedestrian Braking, (TQ5) IntelliBeam, (UFL) Lane Departure Warning, (T8Z) Buckle to Drive and (UHY) Automatic Emergency Braking

Trailer Package includes trailer hitch, 7-pin and 4-pin connectors and (CTT) Hitch Guidance (Deleted when (ZW9) pickup bed delete is ordered.)

Mechanical

Engine, 6.6L V8 with Direct Injection and Variable Valve Timing, gasoline (401 hp [299 kW] @ 5200 rpm, 464 lb-ft of torque [629 N-m] @ 4000 rpm) (STD)

Transmission, Allison 10-Speed automatic (STD)

Rear axle, 3.73 ratio (Requires (L8T) 6.6L V8 gas engine.)

Pickup bed includes bed assist step (STD) (Deleted when (ZW9) pickup bed delete is ordered.)

GVWR, 11,300 lbs. (5126 kg) with single rear wheels (STD) (Included and only available with TC30953 or TK30903 model and (L8T) 6.6L V8 gas engine. Requires single rear wheels.)

Push Button Start

Air filter, heavy-duty

Air filtration monitoring

Transfer case, two-speed electronic shift with push button controls (Requires 4WD models.)

Auto-locking rear differential

Four wheel drive

Cooling, external engine oil cooler

Cooling, auxiliary external transmission oil cooler

Battery, heavy-duty 720 cold-cranking amps/80 Amp-hr maintenance-free with rundown protection and retained accessory power (Included and only available with (L8T) 6.6L V8 gas engine.)

Alternator, 170 amps (Requires (L8T) 6.6L V8 gas engine.)

Recovery hooks, front, frame-mounted, Black

Frame, fully-boxed, hydroformed front section and a fully-boxed stamped rear section

Suspension Package (Not available with (X31) Off-Road Package.)

Steering, Recirculating Ball with smart flow power steering system

Brakes, 4-wheel antilock, 4-wheel disc with DURALIFE rotors

Brake lining wear indicator

Capless Fuel Fill (Requires (L8T) 6.6L gas V8 engine. Not included with (ZW9) pickup bed delete.)

This document contains information considered Confidential between GM and its Clients uniquely. The information provided is not intended for public disclosure. Prices, specifications, and availability are subject to change without notice, and do not include certain fees, taxes and charges that may be required by law or vary by manufacturer or region. Performance figures are guidelines only, and actual performance may vary. Photos may not represent actual vehicles or exact configurations. Content based on report preparer's input is subject to the accuracy of the input provided.

Data Version: 24619. Data Updated: Feb 2, 2025 6:43:00 PM PST.



Todd Wenzel Buick GMC and TW Chevrolet

Albert Li | (734) 713-1065 | ali@toddwenzel.com

[Fleet] 2024 GMC Sierra 3500HD (TK30903) 4WD Reg Cab 142" Pro (12) (✔ Complete)

Exterior

Wheels, 18" (45.7 cm) 8-spoke painted steel, Silver Extended (STD) (Requires single rear wheels.)

Tires, LT275/70R18E all-terrain, blackwall (STD) (Requires single rear wheels.)

Tire, spare LT275/70R18 all-terrain, blackwall (STD) (Included and only available with (QF6) LT275/70R18E all-terrain, blackwall tires with (E63) pickup bed single rear wheel models. Available to order when (ZW9) pickup bed delete and (QF6) LT275/70R18E all-terrain, blackwall tires are ordered with single rear wheel models.)

Single Rear Wheels (STD)

Tire carrier lock keyed cylinder lock that utilizes same key as ignition and door (Deleted with (ZW9) pickup bed delete.)

Bumper, front chrome lower

Bumper, rear chrome with bumper CornerSteps

CornerStep, rear bumper

Bed Step, Black integrated on forward portion of bed on driver and passenger side (Not available with (ZW9) pickup bed delete.)

Moldings, bellline, Black

Cargo tie downs (12), fixed, rated at 500 lbs per corner

Grille, Chrome with flat black grille insert bars

Headlamps, Animated LED projectors, LED turn signals and Daytime Running Lamps

IntelliBeam, automatic high beam on/off (Included and only available with (PDI) Sierra HD Pro Safety.)

Taillamps, LED Signature Tail, Incandescent Brake, Turn & Reverse Lamps (Requires single rear wheels.)

Lamps, cargo area, cab mounted integrated with center high mount stop lamp, with switch in bank on left side of steering wheel

Mirrors, outside power-adjustable vertical trailering with heated upper glass lower convex mirrors, integrated turn signals, manual folding/extending (extends 3.31" [84.25mm]), Black (Standard on regular Cab models.)

Glass, solar absorbing, tinted

Door handles, Black grained

Tailgate, standard (Deleted with (ZW9) pickup bed delete.)

Tailgate and bed rail protection caps, top (Deleted with (ZW9) pickup bed delete.)

Tailgate, locking, utilizes same key as ignition and door (Included and only available with (QK1) standard tailgate. Deleted with (ZW9) pickup bed delete.)

Tailgate, gate function manual, no lift assist (Deleted with (ZW9) pickup bed delete.)

Entertainment

Audio system, GMC Infotainment System with 7" diagonal color touchscreen, AM/FM stereo with seek-and-scan and digital clock, includes Bluetooth streaming audio for music and select phones; featuring wireless Apple CarPlay and Android Auto capable (STD)

This document contains information considered Confidential between GM and its Clients uniquely. The information provided is not intended for public disclosure. Prices, specifications, and availability are subject to change without notice, and do not include certain fees, taxes and charges that may be required by law or vary by manufacturer or region. Performance figures are guidelines only, and actual performance may vary. Photos may not represent actual vehicles or exact configurations. Content based on report preparer's input is subject to the accuracy of the input provided.

Data Version: 24619. Data Updated: Feb 2, 2025 6:43:00 PM PST.



Todd Wenzel Buick GMC and TW Chevrolet

Albert Li | (734) 713-1065 | ali@toddwenzel.com

[Fleet] 2024 GMC Sierra 3500HD (TK30903) 4WD Reg Cab 142" Pro (12) (✔ Complete)

Entertainment

SiriusXM enjoy a Platinum Plan trial subscription (Requires (UE1) OnStar. IMPORTANT: The SiriusXM trial package is not provided on vehicles that are ordered for Fleet Daily Rental ("FDR") use. Trial subscription is subject to the SiriusXM Customer Agreement and privacy policy, visit www.siriusxm.com which includes full terms and how to cancel. All fees, content, features, and availability are subject to change.)

Audio system feature, 2-speakers (Requires Regular Cab model.)

Bluetooth for phone connectivity to vehicle Infotainment system

Wireless Phone Projection for Apple CarPlay and Android Auto

Wi-Fi Hotspot capable (Terms and limitations apply. See onstar.com or dealer for details.)

Interior

Seats, front 40/20/40 split-bench with covered armrest storage and under-seat storage (lockable) (STD)

Seat trim, Vinyl

Seat adjuster, driver 4-way manual

Seat adjuster, passenger 4-way manual

Floor covering, rubberized-vinyl (Not available with LPO floor liners.)

Steering wheel, urethane

Instrument cluster, 6-gauge cluster featuring speedometer, fuel level, engine temperature, tachometer, voltage and oil pressure

Driver Information Center, 3.5" diagonal monochromatic display

Exterior Temperature Display located in radio display

Compass, located in instrument cluster

Window, power front, drivers express up/down

Window, power front, passenger express down

Door locks, power

Remote Keyless Entry

Power outlet, front auxiliary, 12-volt

USB Ports, 2, Charge/Data ports located on instrument panel

Air conditioning, single-zone

Mirror, inside rearview, manual tilt

Assist handles, front A-pillar mounted for driver and passenger, rear B-pillar mounted

GMC Connected Access capable (Included and only available with (UE1) OnStar. Subject to terms. See onstar.com or dealer for details.)

This document contains information considered Confidential between GM and its Clients uniquely. The information provided is not intended for public disclosure. Prices, specifications, and availability are subject to change without notice, and do not include certain fees, taxes and charges that may be required by law or vary by manufacturer or region. Performance figures are guidelines only, and actual performance may vary. Photos may not represent actual vehicles or exact configurations. Content based on report preparer's input is subject to the accuracy of the input provided.

Data Version: 24619. Data Updated: Feb 2, 2025 6:43:00 PM PST.



Todd Wenzel Buick GMC and TW Chevrolet

Albert Li | (734) 713-1065 | ali@toddwenzel.com

[Fleet] 2024 GMC Sierra 3500HD (TK30903) 4WD Reg Cab 142" Pro (12) (✔ Complete)

Safety-Mechanical

Automatic Emergency Braking (Included and only available with (PDI) Sierra HD Pro Safety.)

StabiliTrak, stability control system with Proactive Roll Avoidance and traction control includes electronic trailer sway control and hill start assist

Safety-Exterior

Daytime Running Lamps LED signature lighting

LED Signature DRL's

Safety-Interior

Airbags, Dual-stage frontal airbags for driver and front outboard passenger; Seat-mounted side-impact airbags for driver and front outboard passenger; Head-curtain airbags for front and rear outboard seating positions; Includes front outboard Passenger Sensing System for frontal outboard passenger airbag (Always use seat belts and child restraints. Children are safer when properly secured in a rear seat in the appropriate child restraint. See the Owner's Manual for more information.)

OnStar and GMC connected services capable (Terms and limitations apply. See onstar.com or dealer for details.)

HD Rear Vision Camera (Not available with (ZW9) pickup bed delete. Removed with (UV2) HD Surround Vision or (ZW9) pickup bed delete. Not available with (Z6A) Gooseneck / 5th Wheel Prep Package.)

Hitch Guidance dynamic single line to aid in truck trailer alignment for hitching (Deleted with (ZW9) pickup bed delete.)

Lane Departure Warning (Included and only available with (PDI) Sierra HD Pro Safety.)

Following Distance Indicator (Included and only available with (PDI) Sierra HD Pro Safety.)

Forward Collision Alert (Included and only available with (PDI) Sierra HD Pro Safety.)

Front Pedestrian Braking (Included and only available with (PDI) Sierra HD Pro Safety.)

Teen Driver a configurable feature that lets you activate customizable vehicle settings associated with a key fob, to help encourage safe driving behavior. It can limit certain available vehicle features, and it prevents certain safety systems from being turned off. An in-vehicle report card gives you information on driving habits and helps you to continue to coach your new driver

Buckle to Drive prevents vehicle from being shifted out of Park until driver seat belt is fastened; times out after 20 seconds and encourages seat belt use (Included and only available with (PDI) Sierra HD Pro Safety)

Tire Pressure Monitoring System auto learn, includes Tire Fill Alert (does not apply to spare tire)

Processing-Other

Trailer Information Label provides max trailer ratings for tongue weight, conventional, gooseneck and 5th wheel trailering (Not available with (ZW9) pickup bed delete.)

This document contains information considered Confidential between GM and its Clients uniquely. The information provided is not intended for public disclosure. Prices, specifications, and availability are subject to change without notice, and do not include certain fees, taxes and charges that may be required by law or vary by manufacturer or region. Performance figures are guidelines only, and actual performance may vary. Photos may not represent actual vehicles or exact configurations. Content based on report preparer's input is subject to the accuracy of the input provided.

Data Version: 24618. Data Updated: Feb 2, 2025 6:43:00 PM PST.



Todd Wenzel Buick GMC and TW Chevrolet

Albert Li | (734) 713-1065 | ali@toddwenzel.com

[Fleet] 2024 GMC Sierra 3500HD (TK30903) 4WD Reg Cab 142" Pro (12) (✔ Complete)

Processing-Other

3 Years of OnStar Remote Access. The OnStar Remote Access Plan gives you simplified remote control of your properly equipped vehicle and unlocks a variety of great features in your myCadillac mobile app. See dealer for details. (OnStar Remote Access Plan does not include emergency or security services. Fleet customers will get Fleet Remote Access through OnStar Vehicle Insights. See onstar.com for details and limitations. Available on select Apple and Android devices. Service availability, features and functionality vary by vehicle, device, and the plan you are enrolled in. Terms apply. Device data connection required.)

WARRANTY

Basic Years: 3
Basic Miles/km: 36,000
Drivetrain Years: 5
Drivetrain Miles/km: 60,000
Drivetrain Note: 3.0L & 6.0L Duramax® Turbo-Diesel engines, and certain commercial, government, and qualified fleet vehicles: 5 years/100,000 miles
Corrosion Years (Rust-Through): 6
Corrosion Years: 3
Corrosion Miles/km (Rust-Through): 100,000
Corrosion Miles/km: 36,000
Roadside Assistance Years: 5
Roadside Assistance Miles/km: 60,000
Roadside Assistance Note: 3.0L & 6.0L Duramax® Turbo-Diesel engines, and certain commercial, government, and qualified fleet vehicles: 5 years/100,000 miles
Maintenance Note: First Visit: 12 Months/12,000 Miles

This document contains information considered Confidential between GM and its Clients uniquely. The information provided is not intended for public disclosure. Prices, specifications, and availability are subject to change without notice, and do not include certain fees, taxes and charges that may be required by law or vary by manufacturer or region. Performance figures are guidelines only, and actual performance may vary. Photos may not represent actual vehicles or exact configurations. Content based on report preparer's input is subject to the accuracy of the input provided.

Data Version: 24619. Data Updated: Feb 2, 2025 6:43:00 PM PST.



Todd Wenzel Buick GMC and TW Chevrolet

Albert Li | (734) 713-1065 | ali@toddwenzel.com

Bloomfield Hills Schools

Prepared For: Jacob McDermott

(248) 420-7504

jmcdermott@bloomfield.org

[Fleet] 2024 GMC Savana Cargo Van (TG33705) RWD 3500 155" (2)

TODD WENZEL BUICK GMC of WESTLAND

35100 FORD RD

WESTLAND, MI 48185

State of Michigan MiDeal Contract # 071B7700184

MiDeal Spec # 0125-VAN

Bloomfield Hills Schools Pricing

(MiDeal Pricing)

2024 GMC Savana 3500 Ext Cargo Van

9600# GVWR	4.3L V6 Gas / 8-Spd Auto Trans	Ext Length
SPEC 0125 – 2024 GMC Savana 3500 Cargo Ext Van		\$ 43,513.00
MBK – Masterack Steel Bulkhead Partition w/ Door		\$ 975.00
Total		\$ 44,488.00

Options:

MCP – Masterack Std Commercial Interior Pkg	+\$ 2,175.00
PDL – Prime Design Drop-Down Ladder Rack	+\$ 2,295.00
FTH – (4)-Tier Freon Tank Holder	+\$ 659.00

Prices Quoted are for a MiDeal Dealer Stock Unit.

Availability Subject to Prior Sale.

FOB Bloomfield Hills, MI

REPAIRS
2012 HVAC VAN
108,378
VAN 58



Todd Wenzel Buick GMC and TW Chevrolet

Albert Li | (734) 713-1065 | ali@toddwenzel.com

[Fleet] 2024 GMC Savana Cargo Van (TG33705) RWD 3500 155" (2) (Complete)

Price Summary

PRICE SUMMARY

	MSRP
Base Price	\$44,600.00
Total Options	\$1,715.00
Vehicle Subtotal	\$46,315.00
Destination Charge	\$1,895.00
Grand Total	\$48,210.00

This document contains information considered Confidential between GM and its Clients uniquely. The information provided is not intended for public disclosure. Prices, specifications, and availability are subject to change without notice, and do not include certain fees, taxes and charges that may be required by law or vary by manufacturer or region. Performance figures are guidelines only, and actual performance may vary. Photos may not represent actual vehicles or exact configurations. Content based on report preparer's input is subject to the accuracy of the input provided.

Data Version: 24569. Data Updated: Jan 27, 2025 6:43:00 PM PST.



Todd Wenzel Buick GMC and TW Chevrolet

Albert Li | (734) 713-1065 | ali@toddwenzel.com

[Fleet] 2024 GMC Savana Cargo Van (TG33705) RWD 3500 155" (2) (✔ Complete)

Selected Model and Options

MODEL

CODE	MODEL
TG33705	2024 GMC Savana Cargo Van RWD 3500 155"

COLORS

CODE	DESCRIPTION
GAZ	Summit White

OPTIONS

CODE	DESCRIPTION
ZW9	Body, standard
FE9	Emissions, Federal requirements
LV1	Engine, 4.3L V6
MTH	Transmission, 8-speed automatic, electronically controlled
C6Y	GVWR, 9600 lbs. (4354 kg)
GU6	Rear axle, 3.42 ratio
E24	Door, swing-out passenger-side, 60/40 split
1WT	Work Van Preferred Equipment Group
QB5	Wheels, 4 - 16" x 6.5" (40.6 cm x 16.5 cm) steel
ZLP	Tire, spare LT245/75R16 all-season, blackwall
ZY1	Paint, solid
GAZ	Summit White
AS5	Seats, front bucket with Custom Cloth trim
93G	Medium Pewter, Custom Cloth Seat Trim
ZX2	Seating arrangement, driver and front passenger high-back buckets,
U0F	Audio system, AM/FM stereo with MP3 player
ZQ3	Driver Convenience Package
G80	Differential, heavy-duty locking rear
UA1	Battery, heavy-duty 770 cold-cranking amps, maintenance-free
Z82	Trailer equipment, heavy-duty
UY7	Trailer provisions, trailer wire harness only

This document contains information considered Confidential between GM and its Clients uniquely. The information provided is not intended for public disclosure. Prices, specifications, and availability are subject to change without notice, and do not include certain fees, taxes and charges that may be required by law or vary by manufacturer or region. Performance figures are guidelines only, and actual performance may vary. Photos may not represent actual vehicles or exact configurations. Content based on report preparer's input is subject to the accuracy of the input provided.

Data Version: 24569. Data Updated: Jan 27, 2025 6:43:00 PM PST.



Todd Wenzel Buick GMC and TW Chevrolet

Albert Li | (734) 713-1065 | ali@toddwenzel.com

[Fleet] 2024 GMC Savana Cargo Van (TG33705) RWD 3500 155" (2) (✔ Complete)

OPTIONS

CODE	DESCRIPTION
U05	Horn, dual-note high and low
BA3	Console, engine cover with swing-out storage bin
U80	Compass, 8-point digital located in the Driver Information Center
UFA	Outside temperature display
ATG	Remote Keyless Entry
BTV	Remote vehicle starter system
K34	Cruise control
UTJ	Theft Alarm Notification
—	Visors, driver and front passenger, cloth, padded
TR9	Lighting, auxiliary
Options Total	

This document contains information considered Confidential between GM and its Clients uniquely. The information provided is not intended for public disclosure. Prices, specifications, and availability are subject to change without notice, and do not include certain fees, taxes and charges that may be required by law or vary by manufacturer or region. Performance figures are guidelines only, and actual performance may vary. Photos may not represent actual vehicles or exact configurations. Content based on report preparer's input is subject to the accuracy of the input provided.

Data Version: 24569. Data Updated: Jan 27, 2025 6:43:00 PM PST.



Todd Wenzel Buick GMC and TW Chevrolet

Albert Li | (734) 713-1065 | ali@toddwenzel.com

[Fleet] 2024 GMC Savana Cargo Van (TG33705) RWD 3500 155" (2) (✔ Complete)

Standard Equipment

Package

Power Convenience Package includes (A31) power windows and (AU3) power door locks

Mechanical

Engine, 4.3L V6 with Direct Injection and Variable Valve Timing, includes aluminum block construction (276 hp [206 kW] @ 5200 rpm, 298 lb-ft of torque [404 Nm] @ 3900 rpm) (STD) (Reference the Engine/Axle page for availability.)

Transmission, 8-speed automatic, electronically controlled with overdrive and tow/haul mode. Includes Cruise Grade Braking, Powertrain Grade Braking and Tap-Up/Tap-Down Driver Shift Control (STD) (Requires (LV1) 4.3L gas V6 engine. Reference the Engine/Axle page for availability.)

Rear axle, 3.42 ratio (Reference the Engine/Axle page for availability.)

Body, standard (STD)

GVWR, 9600 lbs. (4354 kg) (STD) (Reference the Engine/Axle page for availability.)

Rear wheel drive

Cooling, external engine oil cooler

Battery, 600 cold-cranking amps, maintenance-free with rundown protection and retained accessory power

Alternator, 105 amps (Not available with (Y3H) Paratransit Package, (YF2) Ambulance Package, (C69) rear air conditioning or (9L7) Wiring junction block equipment accessory.)

Frame, full-length box ladder-type

Suspension, front independent with coil springs and stabilizer bar

Suspension, rear hypoid drive axle with multi-leaf springs

Steering, power

Brakes, 4-wheel antilock, 4-wheel disc

Fuel tank capacity, mid-frame and approximately 31 gallons (117.3L)

Exhaust, aluminized stainless-steel muffler and tailpipe

Exterior

Wheels, 4 - 16" x 6.5" (40.6 cm x 16.5 cm) steel includes Gray center caps and steel spare (STD)

Tire, spare LT245/75R16 all-season, blackwall located at rear underbody of vehicle (STD)

Door, swing-out passenger-side, 60/40 split (STD)

Tires, front LT245/75R16E all-season, blackwall

Tires, rear LT245/75R16E all-season, blackwall

Bumpers, front and rear painted Black with step-pad

Headlamps, dual halogen composite

This document contains information considered Confidential between GM and its Clients uniquely. The information provided is not intended for public disclosure. Prices, specifications, and availability are subject to change without notice, and do not include certain fees, taxes and charges that may be required by law or vary by manufacturer or region. Performance figures are guidelines only, and actual performance may vary. Photos may not represent actual vehicles or exact configurations. Content based on report preparer's input is subject to the accuracy of the input provided.

Data Version: 24569. Data Updated: Jan 27, 2025 6:43:00 PM PST.



Todd Wenzel Buick GMC and TW Chevrolet

Albert Li | (734) 713-1065 | ali@toddwenzel.com

[Fleet] 2024 GMC Savana Cargo Van (TG33705) RWD 3500 155" (2) (✔ Complete)

Exterior

Mirrors, outside heated power-adjustable, Black, manual-folding

Glass, Solar-Ray light-tinted, all windows

Wipers, front intermittent wet-arm with pulse washers

License plate kit, front

Entertainment

Audio system, AM/FM stereo with MP3 player seek-and-scan, digital clock, TheftLock, random select, auxiliary jack and 2 front door speakers (STD) (Not available with (U2K) SiriusXM Radio or (WP9) Communications Package on orders placed prior to October 2, 2023.)

Interior

Seats, front bucket with vinyl trim and head restraints, includes Inboard armrests (STD) (Requires (**W) interior trim.)

Seating arrangement, driver and front passenger high-back buckets, with head restraints and vinyl or cloth trim (STD) (Not available with (AJ3) driver-side only frontal airbag.)

Console, engine cover with open storage bin

Floor covering, full-length Black rubberized-vinyl (Not available with (RFM) rear floor covering delete, (PCH) Hotel Shuttle Package or (YF2) Ambulance Package.)

Steering wheel, steel sleeve column with theft-deterrent locking feature, Black

Instrumentation, analog with speedometer, odometer with trip odometer, fuel level, voltmeter, engine temperature and oil pressure

Oil life monitor

Warning tones, headlamp on and key-in-ignition

Driver Information Center includes fuel range, average speed, oil life, tire pressure monitoring, fuel used, ice warning, engine hours, average fuel economy, tachometer, and maintenance reminders. Compass and outside temperature available if equipped.

Door locks, power with lock-out protection (Included with (ZQ2) Power Convenience Package. NOTE: Does not include (ATG) Remote Keyless Entry. (ATG) Remote Keyless Entry must be ordered separately.)

Windows, power (Included with (ZQ2) Convenience Package.)

Tow/haul mode selector, instrument panel-mounted

Theft-deterrent system, vehicle, PASS-Key III

Power outlets, 2 auxiliary on engine console cover with covers, 12-volt

Power outlet, 120-volt

Air conditioning, single-zone manual

Defogger, side windows

Cup holders, 3 on the engine console cover

This document contains information considered Confidential between GM and its Clients uniquely. The Information provided is not intended for public disclosure. Prices, specifications, and availability are subject to change without notice, and do not include certain fees, taxes and charges that may be required by law or vary by manufacturer or region. Performance figures are guidelines only, and actual performance may vary. Photos may not represent actual vehicles or exact configurations. Content based on report preparer's input is subject to the accuracy of the input provided.

Data Version: 24569. Data Updated: Jan 27, 2025 6:43:00 PM PST.



Todd Wenzel Buick GMC and TW Chevrolet

Albert Li | (734) 713-1065 | ali@toddwenzel.com

[Fleet] 2024 GMC Savana Cargo Van (TG33705) RWD 3500 155" (2) (✔ Complete)

Interior

Trim panels, hinged rear side doors and hinged rear doors (Not available with (Y3H) Paratransit Package.)

Mirror, inside rearview includes Rear Vision Camera display

Headliner, cloth, over driver and passenger

Visors, driver and front passenger, vinyl

Assist handles, driver and right-front passenger

Lighting, interior with 4 dome lights 1 overhead and 3 LED's on cross members in cargo area, includes defeat switch and door handle-activated switches

Cargo tie-downs 6 D-ring attachments on cargo area floor (Not available with (YF2) Ambulance Package, (Y3H) Paratransit Package or (ZP6) 5-passenger Savana Crew Van.)

GMC Connected Access capable (Included and only available with (UE1) OnStar. Subject to terms. See onstar.com or dealer for details.)

Safety-Mechanical

Brake/transmission shift interlock, for automatic transmissions

Hill Start Assist

StabiliTrak, traction assistance and vehicle stability enhancement system

Safety-Exterior

Door beams, steel-side

Daytime Running Lamps

Safety-Interior

Airbags, frontal, front driver and right front passenger includes passenger-side frontal airbag deactivation switch. (Included with (ZX2) driver and right-front passenger high-back bucket seats or (ZP6) 5-passenger Savana Crew Van Package. Not available with (ZX1) driver only high-back bucket seat or (AJ3) driver-side only frontal airbag. Always use seat belts and child restraints. Children are safer when properly secured in a rear seat in the appropriate child restraint. See the Owner's Manual for more information.)

Airbags, seat-mounted side-impact for driver and right-front passenger and roof-rail mounted head-curtain for 1-row coverage with (ZX1) driver only high-back bucket seat or (ZX2) driver and right-front passenger high-back bucket seats, and 2-row coverage with (ZP6) 5-passenger Savana Crew Van Package (Not available with (YF2) Ambulance Package or (Y3H) Paratransit Package. Always use seat belts and child restraints. Children are safer when properly secured in a rear seat in the appropriate child restraint. See the Owner's Manual for more information.)

Airbag deactivation switch, frontal passenger-side (Not available with (AJ3) driver only airbag. Always use seat belts and child restraints. Children are safer when properly secured in a rear seat in the appropriate child restraint. See the Owner's Manual for more information.)

OnStar and GMC connected services capable (Not available with (YF2) Ambulance Package. Terms and limitations apply. See onstar.com or dealer for details.)

Rear Vision Camera display integrated into rearview mirror (Display included with (DRJ) inside rearview mirror.)

This document contains information considered Confidential between GM and its Clients uniquely. The information provided is not intended for public disclosure. Prices, specifications, and availability are subject to change without notice, and do not include certain fees, taxes and charges that may be required by law or vary by manufacturer or region. Performance figures are guidelines only, and actual performance may vary. Photos may not represent actual vehicles or exact configurations. Content based on report preparer's input is subject to the accuracy of the input provided.

Data Version: 24569. Data Updated: Jan 27, 2025 6:43:00 PM PST.



Todd Wenzel Buick GMC and TW Chevrolet

Albert Li | (734) 713-1065 | ali@toddwenzel.com

[Fleet] 2024 GMC Savana Cargo Van (TG33705) RWD 3500 155" (2) (Complete)

Safety-Interior

Tire Pressure Monitoring System (does not apply to spare tire)

WARRANTY

Basic Years: 3
Basic Miles/km: 36,000
Drivetrain Years: 5
Drivetrain Miles/km: 60,000
Drivetrain Note: Certain commercial, government, and qualified fleet vehicles: 5 years/100,000 miles
Corrosion Years (Rust-Through): 6
Corrosion Years: 3
Corrosion Miles/km (Rust-Through): 100,000
Corrosion Miles/km: 36,000
Roadside Assistance Years: 5
Roadside Assistance Miles/km: 60,000
Roadside Assistance Note: Certain commercial, government, and qualified fleet vehicles: 5 years/100,000 miles
Maintenance Note: First Visit: 12 Months/12,000 Miles

This document contains information considered Confidential between GM and its Clients uniquely. The information provided is not intended for public disclosure. Prices, specifications, and availability are subject to change without notice, and do not include certain fees, taxes and charges that may be required by law or vary by manufacturer or region. Performance figures are guidelines only, and actual performance may vary. Photos may not represent actual vehicles or exact configurations. Content based on report preparer's input is subject to the accuracy of the input provided.

Data Version: 24569. Data Updated: Jan 27, 2025 6:43:00 PM PST.



Bloomfield Hills Board of Education

Memo

To: Superintendent and Board of Education
From: Keith McDonald, Deputy Superintendent
Date: February 24, 2025
Re: Request to Approve Personnel Actions

Recommended Motion:

I move the Board of Education to approve the personnel actions, as presented.

Background Information:

ATTACHMENTS:

File Name	Description
Personnel_Report_-_February_24__2025.pdf	Personnel Report (February 24, 2025)

Personnel Report - February 24, 2025

ASSIGNMENTS:

RECALLS:

None to report

RESIGNATIONS:

Michelle Fiebke-Lang

Principal/Way/1.0 FTE

Reason: Personal

Effective: June 20, 2025

Start Date: August 29, 2022

Carmella Lewis

Accounting and Grants Supervisor/Business Services/1.0 FTE

Reason: Personal

Effective: February 21, 2025

Start Date: September 5, 2023

LAYOFFS:

None to report

LEAVE OF ABSENCE:

Sarah Sirvoy

Teacher/Lone Pine 1.0 FTE

Reason: Unpaid Child Care Leave for remainder of 2024-2025 School Year

Effective: January 28, 2025

Hire Date: August 27, 2015



Bloomfield Hills Board of Education

Memo

To: Superintendent and Board of Education
From: Allen Dresselhouse and David Goldman, Plante Moran Realpoint
Date: February 24, 2025
Re: Bond Quarterly Report

Recommended Motion:

Background Information:

ATTACHMENTS:

File Name	Description
 25.02.24_Bloomfield_Hills_Schools_2020_Bond_Quarterly_Report.pdf	Bond Quarterly Report (February 24, 2025)

Bloomfield Hills Schools

2020 Bond Program Quarterly Update
February 24, 2025





Bloomfield Hills Schools 2020 Bond Program | Quarter 1 Dashboard Report

BHS 2020 Bond Program Budget: \$207,955,000

FUNDING ALLOCATION:	Projected Budget	Projected Commitments	Actuals Approved	Actual Cost To Complete	Forecasted Commitments	Unallocated Reserve	Estimate At Completion	Forecasted Over/(Under)
Professional Fees	\$ 17,271,610	\$ 15,838,811	\$ 12,784,207	\$ 3,054,604	\$ (76,197)	\$ -	\$ 15,762,614	\$ (1,508,996)
Construction	\$ 160,036,849	\$ 150,637,042	\$ 125,980,729	\$ 24,656,313	\$ 10,634,709	\$ -	\$ 161,271,751	\$ 1,234,902
Technology	\$ 19,743,172	\$ 17,227,545	\$ 11,971,630	\$ 5,255,915	\$ 2,515,627	\$ -	\$ 19,743,172	\$ -
Furniture & Equipment	\$ 10,903,369	\$ 5,194,555	\$ 5,194,555	\$ -	\$ 5,708,814	\$ -	\$ 10,903,369	\$ -
OVERALL TOTALS:	\$207,955,000	\$188,897,953	\$155,931,121	\$32,966,832	\$18,782,953	\$0	\$207,680,906	(\$274,094)

Note: Misc. Owner Cost through October 2024

Professional Fees Budget Includes Interest Earnings through August 2024

Budget Breakdown

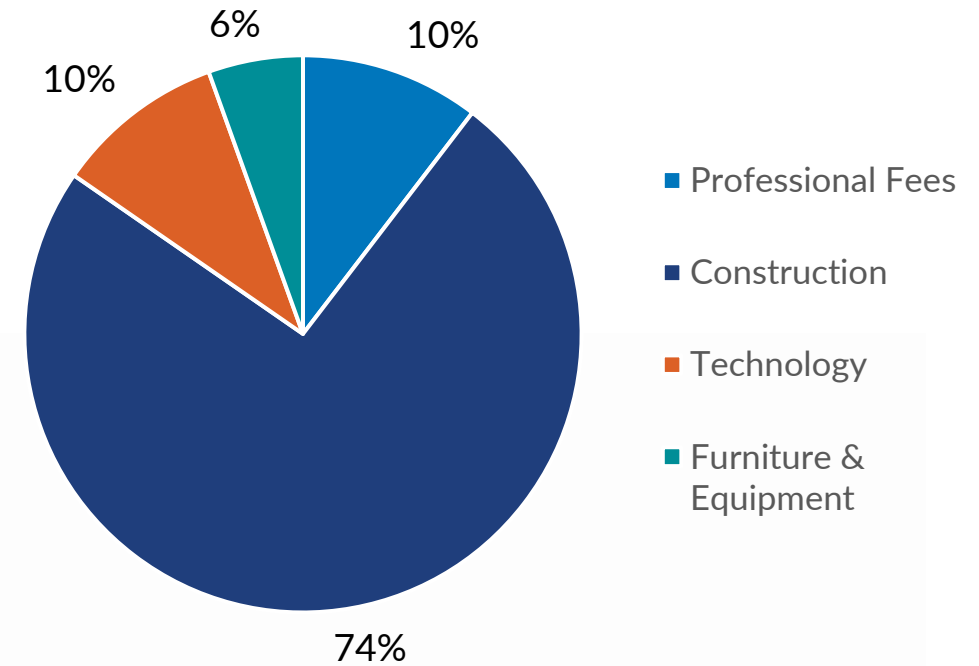

Project Schedule

Descriptions

- District Wide Renovations
- District Wide Renovations
- Playground Equipment
- Playground Sitework
- District Wide Moving and Final Cleaning
- Early Childhood Renovations- (Bloomin East)
- High School Baseball & Softball Sitework
- High School Athletic Renovations & Addition
- High School Athletic Gateway / Restroom Bldg. / Art Room Storm Water Corrections
- Elementary Schools - Phase II / Sanitary Repairs (NHMS) / Technology
- Fox Hills Demolition
- Elementary Schools - Phase III / IA, Wing Lake Secure Vestibules
- Lone Pine Exterior Entryway
- Bloomin West / Robotics Renovations
- Bowers Farm
- Transportation / Maintenance Renovations / Nature Center
- Booth Center Renovations

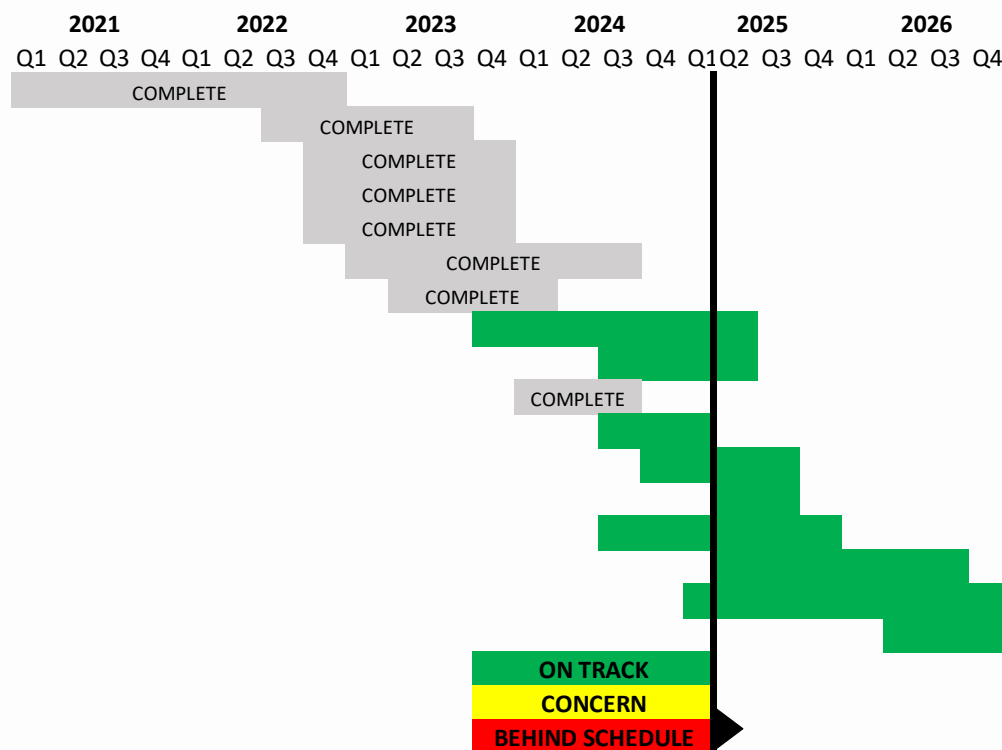

Under Construction / Upcoming Work - 2025 and Beyond

- High School Wellness Center and Concessions
- High School Gateway Entrance and Restroom Building
- Fox Hills Building Demolition
- Lone Pine Exterior Entryway
- International Academy Secure Vestibule
- Elementary School Phase III Renovations
- Bloomin West/ Robotics/ Maintenance Building Renovations
- Bowers Farm, Nature Center, and Wing Lake Renovations
- Transportation Renovation and Expansion
- Booth and High School Renovations

Note - Numbers and dates on this report are subject to change





Exterior of Wellness Center



Interior of Wellness Center



Interior of Wellness Center



Interior of Wellness Center

2025 District Projects- In Progress – High School Gateway / Restrooms



Gateway (Rendering)



Restroom Building (Rendering)



Future Restroom Building



Future Restroom Building

2025 District Projects- In Progress – Bloomin West / Robotics



Interior Demolition



Future Robotics

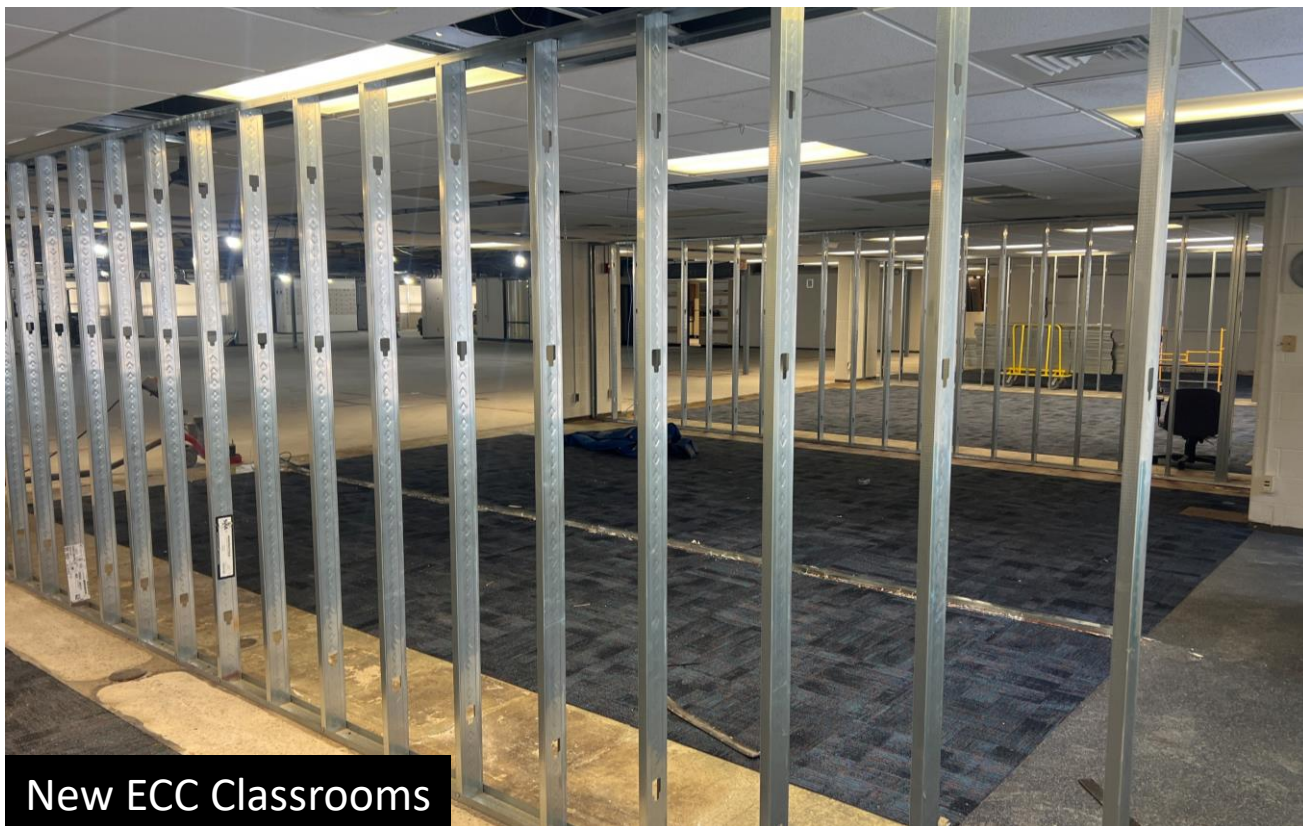

New ECC Classrooms

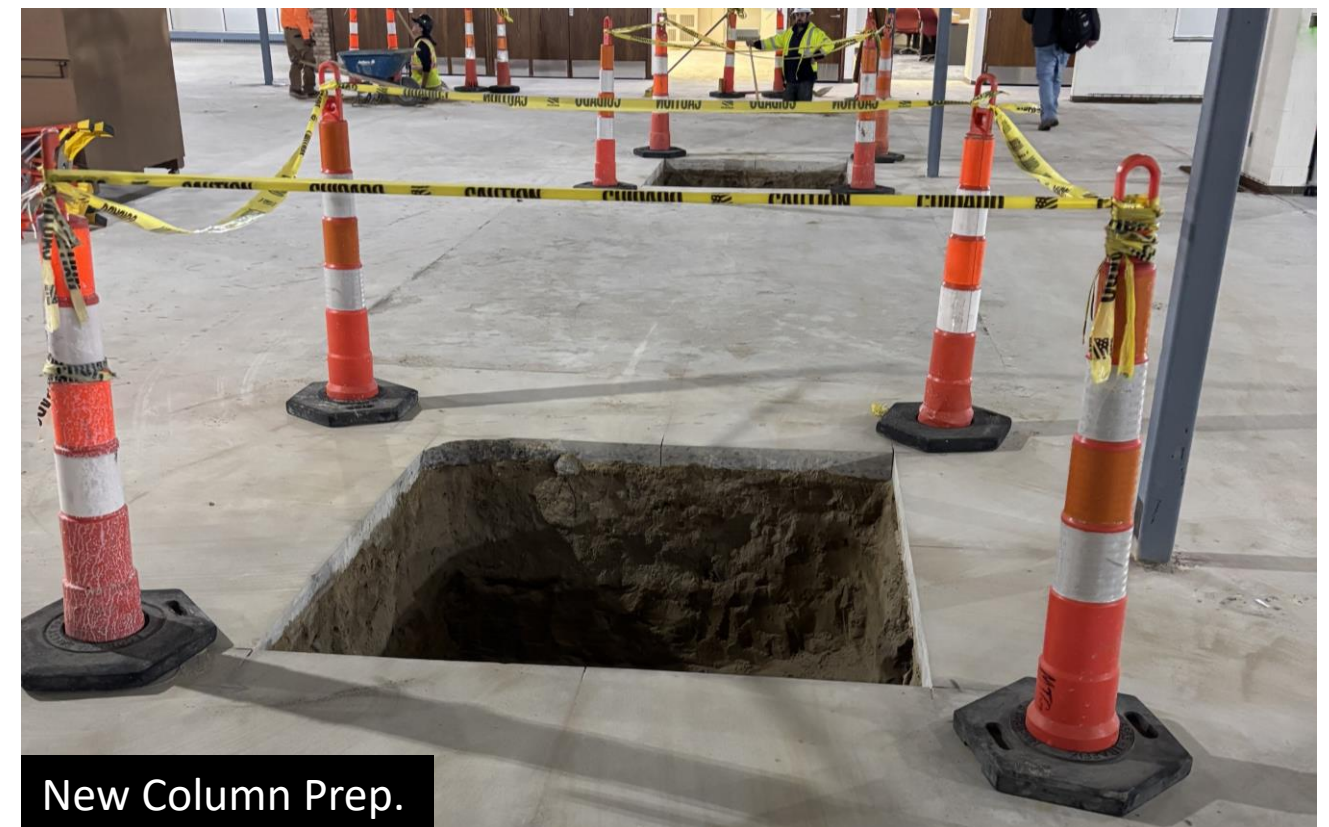

New Column Prep.

2025 District Projects- In Progress – Fox Hills (Demo)





Bloomfield Hills Board of Education

Memo

To: Superintendent and Board of Education
From: Jacob McDermott, Director of Maintenance and Operations
Date: February 24, 2025
Re: Request to Award Bid #1052 - Asbestos Abatement (Conant, Eastover, Lone Pine and Way Elementary Schools)

Recommended Motion:

I move the Board of Education to award RFP #1052 to Environmental Maintenance Engineers, Inc. for asbestos abatement Conant, Eastover, Lone Pine and Way Elementary Schools in the amount of \$90,000, to be paid from the Bond Fund, as presented.

Background Information:

On January 20, 2025, bids were received from six (6) contractors for asbestos abatement activities for Conant, Eastover, Lone Pine and Way Elementary Schools. All post bid interviews have been conducted and qualified to meet the criteria set forth in the RFP for submission. The breakdown of the work for this bid package along with the bid tabulation and award documentation is enclosed for review. We are requesting board approval so that work and overall project material procurement can commence immediately. Project funding will be coming directly from the 2020 bond program budget.

ATTACHMENTS:

File Name	Description
☐ RFP_1052_Asbestos-Conant__EO__LP__Way.pdf	RFP 1052 - Asbestos Abatement



Plante Moran Realpoint
 3000 Town Center, Suite 100
 Southfield, MI 48075
 Tel: 248.223.3500 | Fax: 248.223.3150
 pmrealpoint.com

January 27, 2025

Mr. Keith McDonald, Deputy Superintendent
 Mr. Jacob McDermott, Director of Physical Plant Services
 Bloomfield Hills Schools
 7273 Wing Lake Rd
 Bloomfield Hills, MI 48301

RE: BHS Bond – Bid Package #11 (Conant, Eastover, Lone Pine, Way) – Asbestos Abatement

Dear Mr. McDonald and Mr. McDermott:

On January 20, 2025, bids were received from six (6) contractors for asbestos abatement activities for Conant, Eastover, Lone Pine and Way Elementary Schools. All post bid interviews have been conducted and qualified to meet the criteria set forth in the RFP for submission. The breakdown of the work for this bid package along with the bid tabulation and award documentation is enclosed for review. We are requesting board approval so that work and overall project material procurement can commence immediately. Project funding will be coming directly from the 2020 bond program budget.

Funding Breakdown:

Environmental Maintenance Engineers, Inc.	\$75,000.00
20% contingency	\$15,000.00
Grand total	\$90,000.00

In conclusion, the project team is requesting board approval of the demolition work and contingency in the amount of **\$90,000.00** to be issued to the lowest qualified bidders as outlined below. A 20% contingency is being carried for this project due to the many unknowns that might come up during the removal process.

The Project Team is available at the Board’s convenience to answer any questions.

Sincerely,

David Goldman
 Plante Moran Realpoint

CC: Kandice Moynihan – Bloomfield Hills Schools
 Kayleen Krahn – Bloomfield Hills Schools
 Rebecca Catherincchia - Bloomfield Hills Schools
 Paul Wills, Shannon Momot, Allen Dresselhouse– Plante Moran Realpoint



www.archenvgroup.com
healthAIR - Industrial Hygiene Services
cleanWATER - Consulting & Testing Services
safeEARTH - Hazardous Waste & Recycling Services

CONTRACT AWARD REQUEST
Environmental Projects

January 20, 2025

Mr. Ken Vavruska
Assistant Director of Maintenance and Operations
Bloomfield Hills Schools
281 Enterprise Ct., Suite 300
Bloomfield Hills, Michigan 48303
kvavruska@bloomfield.org

RE: **Contract Award Request for RFP#1052**
Asbestos Abatement
Environmental Maintenance Engineers, Inc.
Conant, Eastover, Way, and Lone Pine Elementary Schools

Dear Mr. Vavruska:

Sealed bids for asbestos abatement activities at Conant, Eastover, Way, and Lone Pine Elementary Schools were received on Monday, January 20, 2025, and opened by representatives of Arch Environmental Group, Inc. (AEG) and Bloomfield Hills Schools. AEG has reviewed and evaluated the submitted bid from the low bidder, Environmental Maintenance Engineers, Inc. and conducted a post-bid meeting to discuss the scope of work and schedule for RFP#1052 ("Asbestos Abatement at Conant, Eastover, Way, and Lone Pine Elementary Schools"). AEG has determined that the submitted bid was inclusive and correct. **AEG requests that a Purchase Order or contract be issued in the amount shown to:**

<u>Contractor</u>	<u>Contract Award</u>
Environmental Maintenance Engineers, Inc. 25851 Trowbridge Inkster, Michigan 48141 Phone: (313) 791-2600 Fax: (313) 791-2601	\$75,000.00

A complete bid tabulation for the bid with the selected bid highlighted is attached, as well as copies of Environmental Maintenance Engineers, Inc.'s submitted bid form for RFP#1052, "Familial Relationship Disclosure Statement", and "Affidavit of Compliance – Iran Economics Sanctions Act".

Please show your approval to issue a Purchase Order or contract to Environmental Maintenance Engineers, Inc. by signing the "Approved By" section below (following formal approval by the Board of Education) and returning one copy of this letter to our office. AEG will coordinate with Bloomfield Hills Schools for the issuance of a Purchase Order or contract after receiving your approval of this Contract Award Request.

Approved By: _____
Bloomfield Hills Schools

Date: _____

DETROIT
(248) 426-0165
Farmington Hills, MI

GRAND RAPIDS
(616) 930-4116
Cedar Springs, MI

CHICAGO
(847) 462-9687
Cary, IL

Contract Award Request for RFP #1052

Environmental Maintenance Engineers, Inc.
Bloomfield Hills Schools
Conant, Eastover, Way, and Lone Pine Elementary Schools
Page 2

Arch Environmental Group, Inc. looks forward to working with you in the future and helping you to address any concerns regarding environmental health and safety. If you have any questions regarding this recommendation or require any additional documentation in support of Environmental Maintenance Engineers, Inc., please feel free to contact me at (248) 426-0165.

Sincerely,

Arch Environmental Group, Inc.
Environmental Services

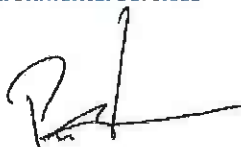

Pedro Pacheco
Project Consultant II, healthAIR

Attachments: RFP#1052 Bid Tabulation
Submitted bid forms for RFP#1052
Submitted "Familial Relationship Disclosure Statement"
Submitted "Affidavit of Compliance – Iran Economics Sanctions Act"

cc: Mr. Jeff Cheney, Environmental Maintenance Engineers, Inc.

File: AE240922



ATTACHMENT A

PROPOSAL PRICING FORM

CONTRACTOR INFORMATION:

CONTRACTOR'S NAME: Environmental Maintenance Engineering, Inc
CONTACT PERSON: Jeff Cheney
ADDRESS: 25851 Trowbridge
CITY/STATE: Inkster, MI 48141
TELEPHONE NUMBER: 313-791-2600
FAX NUMBER: 313-791-2601
E-MAIL ADDRESS: J.Cheney@TeamEMF.com

A. CONTRACTOR PRICING

RFP 1052 Asbestos Abatement Elementary Schools – TOTAL COMBINED PRICE	\$ 75,000 ⁰⁰
Conant Elementary School – Schedule of Value	\$ 36,000 ⁰⁰
Eastover Elementary School – Schedule of Value	\$ 4,500 ⁰⁰
Lone Pine Elementary School – Schedule of Value	\$ 7,800 ⁰⁰
Way Elementary School – Schedule of Value	\$ 26,700 ⁰⁰
Alternate Bid Eastover Elementary School – Schedule of Value	\$ 35,000 ⁰⁰
Per Linear Foot/Per Fitting Price UNIT PRICE	\$ 23 ⁰⁰ / \$ 35 ⁰⁰
Contractor Per Man Hour Rate UNIT PRICE	\$ 88 ⁰⁰
Contractor per Fitting/Per Linear Foot – UNIT PRICE	\$ 35 ⁰⁰ / \$ 23 ⁰⁰
Electrical Power UNIT PRICE	\$ 6,900 ⁰⁰
Water UNIT PRICE	\$ 1,500 ⁰⁰
Mobilization – UNIT PRICE	\$ 700 ⁰⁰

B. ACKNOWLEDGEMENT OF ADDENDA TO RFP #1052

The Contractor acknowledges receipt of the following addenda:

Addendum Number 1 dated 1/15/25
Addendum Number _____ dated _____
Addendum Number _____ dated _____

The undersigned understands that the School District reserves the right to accept or reject in whole or in part any and all Proposals, to waive informalities and irregularities therein, and to award the Contract to other than the Contractor(s) submitting the best financial Proposal (low proposer) and to award the Contract to one (1) or more Contractors in the School District's sole and absolute discretion.

If award is made to our firm based upon our Proposal, we agree to enter into the attached form of Contract with the School District to furnish the Work in strict accordance with this Request for Proposal, the Contract and our Proposal.

My signature certifies that the Proposal as submitted complies with all terms and conditions as set forth in this Request for Proposal and the Contract, unless specifically enumerated as an exception as part of our Proposal.

I hereby certify that I am authorized to sign as a Representative for the firm.

THE CONTRACTOR HEREBY SUBMITS THIS PROPOSAL PRICING FORM IN ACCORDANCE WITH THE TERMS AND CONDITIONS OF THE RFP.

Name of Contractor: Environmental Maintenance Engineers, Inc.

(Signature/Principal)

Jeffrey A. Cloney
(Name Printed)

Date: 1/17/25

ATTACHMENT B

FAMILIAL DISCLOSURE AFFIDAVIT

The undersigned, the owner or authorized officer of EME (the "Contractor"), pursuant to the familial disclosure requirement provided in the Bloomfield Hills School's (the "School District") Request for Proposals #1052 Asbestos Abatement Conant, Eastover, Lone Pine and Way Elementary Schools, hereby represents and warrants that, except as provided below, no familial relationships exist between the owner or any employee of the Contractor, and any member of the Board of Education of the School District or the Superintendent of the School District. A list of the School District's Board of Education Members and its Superintendent may be found at <http://www.bloomfield.org>.

List any Familial Relationships: None

CONTRACTOR:

Environmental Maintenance Engineers, Inc

By: Jeffery A. Clark

Its: Vice President

STATE OF Michigan
COUNTY OF Wayne)ss.

This instrument was acknowledged before me on the 16th day of January, 2025 by Amanda Quick

Amanda Quick

, Notary Public

Wayne County, Michigan

My Commission Expires: November 4th, 2029

Acting in the County of: Wayne

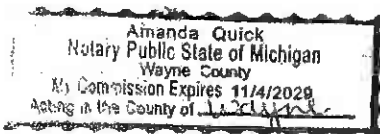

ATTACHMENT C

IRAN ECONOMIC SANCTIONS ACT AFFIDAVIT OF COMPLIANCE

Michigan Public Act No. 517 of 2012

The undersigned, the owner or authorized officer of the below-named contractor ("Contractor"), pursuant to the compliance certification requirement provided in the Bloomfield Hills Schools' (the "School District") Request for Proposals #1052 Asbestos Abatement Conant, Eastover, Lone Pine and Way Elementary Schools (the "RFP"), hereby certifies, represents and warrants that the Contractor (including its officers, directors and employees) is not an "Iran linked business" within the meaning of the Iran Economic Sanctions Act, Michigan Public Act No. 517 of 2012 (the "Act"), and that in the event Contractor is awarded a contract as a result of the aforementioned RFP, the Contractor will not become an "Iran linked business" at any time during the course of performing any Work under the Contract.

The Contractor further acknowledges that any person who is found to have submitted a false certification is responsible for a civil penalty of not more than \$250,000.00 or 2 times the amount of the contract or proposed contract for which the false certification was made, whichever is greater, the cost of the School District's investigation, and reasonable attorney fees, in addition to the fine. Moreover, any person who submitted a false certification shall be ineligible to propose on a Request for Proposal for three (3) years from the date it is determined that the person has submitted the false certification.

CONTRACTOR:

Environmental Maintenance Engineers, Inc.
(Name of Contractor)

By: Jeffery A. Cheney

Its: Vice President

Date: 1/16/2025

STATE OF Michigan)

COUNTY OF Wayne) ss.

This instrument was acknowledged before me on the 16th day of January, 2025 by

Amanda Quick

Amanda Quick

, Notary Public

Wayne County, Michigan

My Commission Expires: November 4th 2029

Acting in the County of Wayne

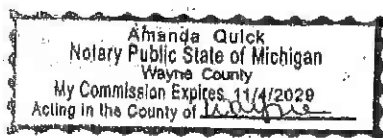



Bloomfield Hills Board of Education

Memo

To: Superintendent and Board of Education
From: Jacob McDermott, Director of Maintenance and Operations
Date: February 24, 2025
Re: Request to Award Bid #1050 - Roof Work (Bloomfield Hills High School, Conant and Eastover Elementary Schools)

Recommended Motion:

I move the Board of Education to award RFP #1050 to Tri-Star Roofing to replace sections of the roofs at Bloomfield Hills High School, Conant Elementary School, and Eastover Elementary School in the amount of \$1,058,970, to be paid from the Sinking Fund, as presented.

Background Information:

On January 21, 2025, drawings and specifications were released for roof replacements at Bloomfield Hills High School, Conant Elementary School, and Eastover Elementary School through BidNet Direct. Bids were received on February 4, 2025 with nine (9) companies responding to the RFP. The funding for the project will come from the district's Sinking Fund. We are requesting Board approval so that the work can commence immediately in order to be substantially complete by August 15, 2025.

ATTACHMENTS:

File Name	Description
📎 RFP_1050_Roof-BHHS__Conant__EO.pdf	RFP 1050 - ROOF WORK

RE: Bloomfield Hills High School Roof Replacement

Conant Elementary School Roof Replacement

Eastover Elementary School Roof Replacement

RFP #1050

On January 21, 2025, drawings and specifications were released for roof replacements at Bloomfield Hills High School, Conant Elementary School, and Eastover Elementary School through BidNet Direct. Bids were received on February 4, 2025 with nine (9) companies responding to the RFP. The funding for the project will come from the district's Sinking Fund. We are requesting Board approval so that the work can commence immediately in order to be substantially complete by August 15, 2025.

The breakdown of the work is listed below. The bid tabulation is also attached for your reference.

Bid Tabulation:

New Roofing (Bloomfield Hills HS): \$207,400.00

New Roofing (Conant ES): \$396,300.00 (base bid only)

New Roofing (Eastover ES): \$364,000.00

Multiple Project Deduct: (\$ 5,000.00) – if awarded all three (3) base bid projects

Construction Contingency (10%): \$ 96,270.00

Total: \$1,058,970.00

** The above Base Bid amounts include a total allowance of \$100,000.00 for gas lines, electrical conduits, and other

items that need to be raised / relocated, etc. (BHHS - \$25,000, Conant - \$50,000, and Eastover - \$25,000).

Bloomfield Hills Maintenance and operations is seeking the approval of \$1,058,970.00 from the district's Sinking Fund to move forward with Tri-Star Roofing & Sheet Metal's competitive bid. They are a reputable roofing company, have completed numerous projects / repairs for similar districts and customers, and we believe that they would be able to complete the projects as required.



BID TABULATION

February 4, 2025

Bloomfield Hills Schools
 District-Wide Roofing Replacement
 Project No. 6524 (RFP #1050)

Contractor	Familial Disclosure Provided?	Iran Economic Sanctions Provided?	Bid Bond Provided?	Base Bid #1 Amount (Bloomfield Hills High School)	Base Bid #2 Amount (Conant Elem. School)	Alternate #1 - Vespene Floor Protection (Conant Elem. School)	Base Bid #2 Proposal - Alternate #1 (Conant Elem. School)	Base Bid #3 Amount (Eastover Elem. School)	Base Bid #1, #2, and #3 Proposals Only	Base Bid #1, #2, and #3 Proposals + Alternates #1	Deduct for multiple Project Award (2 projects)	Deduct for multiple Project Award (3 projects)	Clarifications
Butcher & Butcher Construction Co.	Y	Y	Y	No Bid	\$544,248.00		\$544,248.00	\$495,940.00			N/A	N/A	Note 1
CEI Michigan LLC	Y	Y	Y	\$546,200.00	\$772,900.00	\$28,950.00	\$801,850.00	\$773,500.00	\$2,114,600.00	\$2,143,550.00	\$0.00	\$0.00	
JD Candler Roofing Co.	Y	Y	Y	No Bid	No Bid	N/A	N/A	\$585,000.00			N/A	N/A	Note 1
Newton Crane Roofing, Inc.	Y	Y	Y	\$550,000.00	\$1,110,000.00	\$30,000.00	\$1,140,000.00	\$1,010,000.00	\$2,670,000.00	\$2,700,000.00	N/A	N/A	Note 3
Royal Roofing Company, Inc.	Y	Y	Y	\$379,906.00	\$645,000.00	\$2,500.00	\$646,364.00	\$548,700.00	\$1,591,600.00	\$1,591,600.00	\$0.00	\$0.00	Notes 1 & 2
Schena Roofing & Sheet Metal Co.	Y	Y	Y	\$339,645.00	\$665,864.00	\$2,500.00	\$668,364.00	\$682,460.00	\$1,687,949.00	\$1,690,469.00	\$0.00	\$0.00	
Superior Services RSH, Inc.	Y	Y	Y	\$297,200.00	\$598,900.00	\$4,500.00	\$603,400.00	\$447,500.00	\$1,283,400.00	\$1,288,100.00	N/A	N/A	
Tri-Star Roofing & Sheet Metal	Y	Y	Y	\$207,400.00	\$336,300.00	\$2,000.00	\$338,300.00	\$366,000.00	\$967,700.00	\$967,700.00	\$2,500.00	\$5,000.00	Notes 1 & 4
Unlimited Construction	Y	Y	Y	No Bid	No Bid	N/A	N/A	\$492,924.00			N/A	N/A	

Note 1: Did not use the correct Bid Form issued in Addendum #1 and therefore doesn't have the alternate cost or cost of the bonds broken down by each base bid

Note 2: Contractor provided several qualifications to its bid

Note 3: Contractor provided several qualifications to its bid, including items pertaining to the schedule if all 3 projects are awarded to it

Note 4: Contractor provided alternate and bond costs after the bid opening as requested.

BID TABULATION (UNIT PRICES)

February 4, 2025

Bloomfield Hills Schools
 District-Wida Roofing Replacement
 Project No. 6524 (RFP #1058)

Contractor	Metal Deck Replac. (SF)	Metal Deck Repair (SF)	Deck Anti-corr. Treat. (SF)	Tectum Deck Replac. (SF)	Concrete Deck Replac. (SF)	1/2" H.D. S50 Cover board (SF)	Asphalt Base Sheet (SF)	New Roof Drain (EA)	1" x 4" Wood Blocking (LF)	1" x 6" Wood Blocking (LF)	1" x 8" Wood Blocking (LF)	2" x 4" Wood Blocking (LF)	2" x 6" Wood Blocking (LF)	2" x 8" Wood Blocking (LF)	2" x 10" Wood Blocking (LF)	4" x 4" Cant (LF)	2" x 2" Cant (LF)	3/4" Plywood (SF)	Walkway Pads (EA)	Perform Add'l Roof Repair Work (Hour)	Time & Material Mark-up (%)	Notes	
Butcher & Butcher Construction Co	\$15.95	\$8.50	\$4.25	\$28.00	\$28.50	\$4.95	Varies	\$2,250.00	\$7.00	\$5.00	\$8.50	\$4.00	\$6.00	\$7.00	\$8.50	N/A	N/A	\$9.25	\$40.00	\$65.00	15%		
CEI Michigan LLC	\$9.75	\$3.75	\$2.85	\$42.50	\$45.75	\$5.25	\$3.25	\$2,250.00	\$3.50	\$4.00	\$4.50	\$4.50	\$5.00	\$5.50	\$6.00	\$2.25	\$1.25	\$5.25	\$65.25	\$120.00	15%		
JD Candier Roofing Co.	\$12.00	\$6.00	\$10.00	T&M	T&M	\$4.50	\$3.50	\$3,500.00	\$5.00	\$6.00	\$7.00	\$7.00	\$7.50	\$9.50	\$9.50	\$6.50	\$5.00	\$6.00	\$75.00	\$115.00	15%		
Newton Crane Roofing, Inc.	\$26.00	\$14.00	\$9.00	T&M	T&M	\$4.00	\$4.00	\$2,800.00	\$4.50	\$5.00	\$6.00	\$7.00	\$7.50	\$9.00	\$9.00	\$7.00	\$6.00	\$6.00	\$85.00	\$100.00	15%		
Royal Roofing Company, Inc.	\$15.00	\$8.00	\$4.00	\$35.00	\$55.00	\$7.00	\$4.00	\$2,500.00	\$3.00	\$4.00	\$5.00	\$4.00	\$5.00	\$7.00	\$7.00	\$6.00	\$4.00	\$4.00	\$70.00	\$109.00	15%		
Schena Roofing & Sheet Metal Co.	\$14.00	\$2.00	\$3.00	\$24.00	\$18.00	\$4.00	\$2.50	\$1,800.00	\$1.25	\$1.50	\$1.75	\$2.25	\$2.50	\$3.00	\$3.50	\$2.50	\$2.00	\$5.00	\$75.00	\$100.00	10%		
Superior Services RSH, Inc.	\$14.00	\$14.00	\$8.00	\$18.00	\$24.00	\$2.00	\$3.25	\$1,350.00	\$4.00	\$4.50	\$4.75	\$4.00	\$4.50	\$4.75	\$4.85	\$4.00	\$3.00	\$4.00	\$55.00	\$125.00	10%		
Tri-Star Roofing & Sheet Metal	\$15.00	\$15.00	\$15.00	\$15.00	\$15.00	\$7.00	\$4.50	\$800.00	\$3.75	\$4.00	\$4.25	\$5.00	\$5.50	\$5.75	\$6.00	\$4.00	\$4.00	\$5.00	\$50.00	\$72.50	25%		
Unlimited Construction	\$12.50	\$6.50	\$7.00	\$45.00	\$45.00	\$4.00	\$7.00	\$650.00	\$2.50	\$5.00	\$3.50	\$3.00	\$3.50	\$4.00	\$4.50	\$3.50	\$2.50	\$2.50	\$75.00	\$120.00	10%		

Note A:
 Note B:

Structure TEG
 Total Building Envelope Management Solutions
 4777 Campus Drive • Kalamazoo, MI 49008
 1121 Lake Cook Road, Ste C • Deerfield, IL 60015
 473 Airport Road, Ste 1 • Butler, PA 16002
 34119 W. Twelve Mile Road, Ste 270 • Farmington Hills, MI 48331

ROOF AREA DESIGNATION PLAN
 2019 ROOF ASSET MANAGEMENT PROGRAM
 EAST HILLS MIDDLE SCHOOL
 2800 KENSINGTON RD. BLOOMFIELD TWP., MI 48304

REVISIONS / ADDENDA:	
SCALE:	N.T.S.
APPROVED BY:	M.W.P.
DRAWN BY:	R.A.L.C.F.
DATE:	AUGUST 2019
PROJECT NUMBER:	T19099
DRAWING NUMBER:	RAMP-9

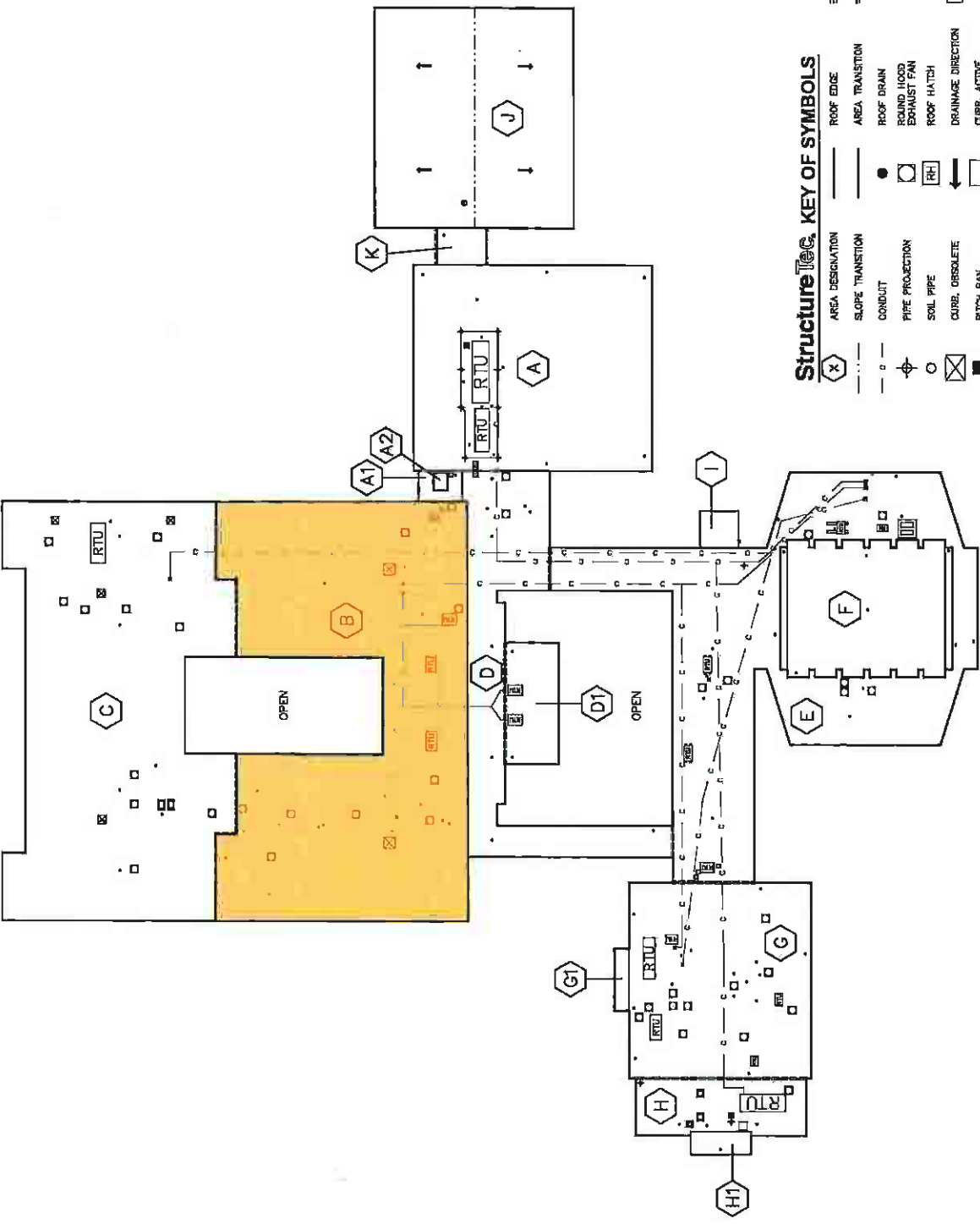

Structure TEG, KEY OF SYMBOLS

	AREA DESIGNATION		ROOF EDGE		EXPANSION JOINT
	SLOPE TRANSITION		AREA TRANSITION		GUTTER
	CONDUIT		ROOF DRAIN		RTU
	PIPE PROJECTION		ROUND HOOD EXHAUST FAN		SQUARE HOOD EXHAUST FAN
	SOIL PIPE		ROOF HATCH		STACK PROJECTION
	CURB, OBSOLETE		DRAINAGE DIRECTION		BRICK CHIMNEY
	PITCH PAN		CURB, ACTIVE		AIR CONDITIONING UNIT

Structure **Tec**®
 Total Building Envelope Management Solution™
 4777 Campus Drive • Kalamazoo, MI 49008
 1121 Lake Cook Road, Ste C • Deerfield, IL 60015
 479 Airport Road, Ste 1 • Butler, PA 16002
 34119 W. Twelve Mile Road, Ste 270 • Farmington Hills, MI 48331

ROOF AREA DESIGNATION PLAN
 2019 ROOF ASSET MANAGEMENT PROGRAM
 BLOOMFIELD HILLS HIGH SCHOOL
 4200 ANDOVER RD, BLOOMFIELD HILLS, MI 48302

REVISIONS / APPROVALS:
SCALE: N.T.S.
APPROVED BY: M.W.P.
DRAWN BY:
DATE: AUGUST 2019
PROJECT NUMBER: T19089
DRAWING NUMBER: RAMP-1

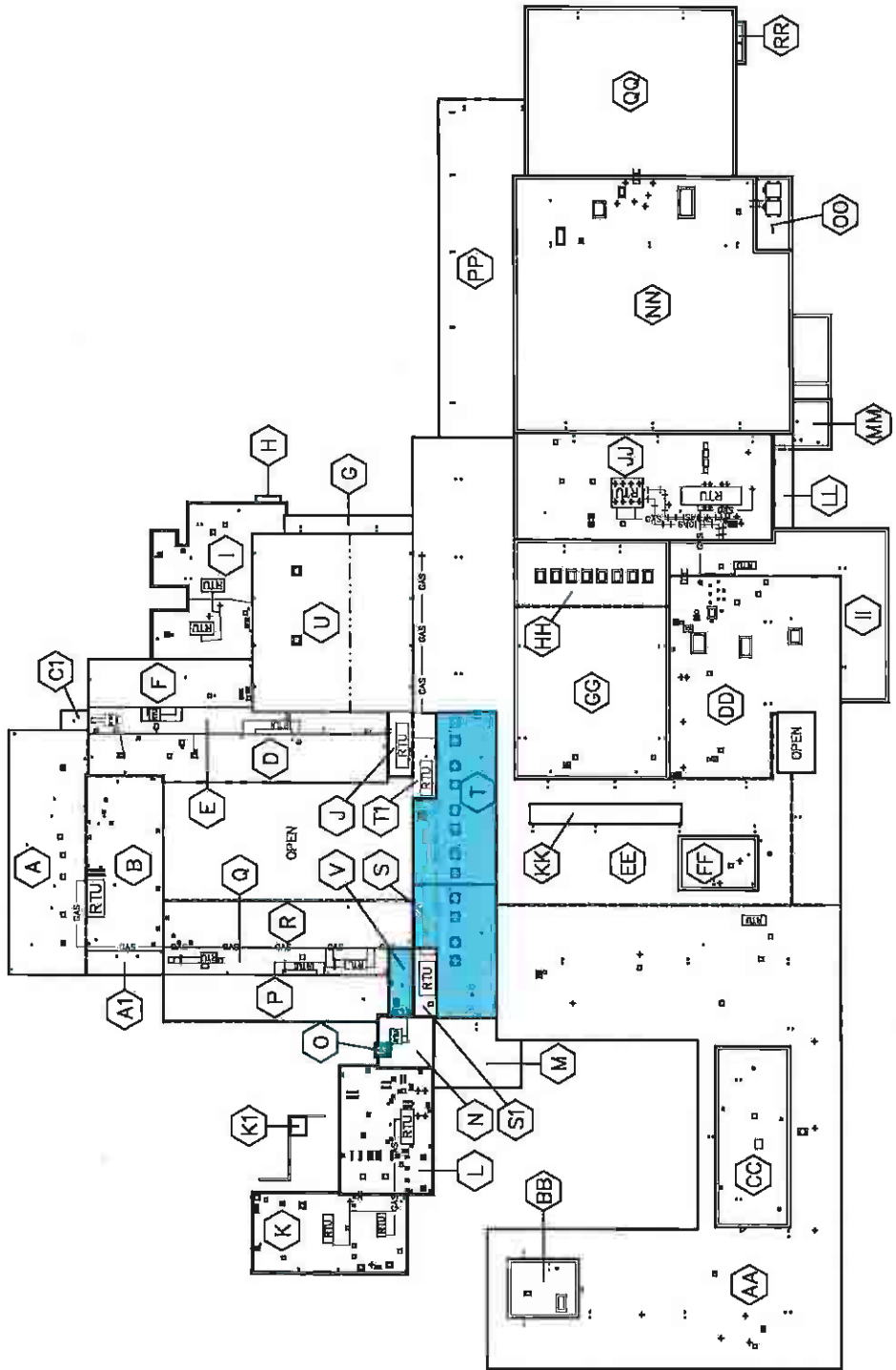

Structure **Tec® KEY OF SYMBOLS**

(X) AREA DESIGNATION	— ROOF EDGE	□ SQUARE HOOD	⊗ ROOF HATCH
- - - SLOPE TRANSITION	- - - AREA TRANSITION	— EXHAUST FAN	⊙ ROOF TOP UNIT
□ AIR CONDITIONING UNIT	⊗ CURB, OBSOLETE	— LADDER	☒ SKYLIGHT
□ CURB, ACTIVE	⊗ PENETRATION POCKET	— PIPE PROJECTION	○ SOIL PIPE
	⊗ EXPANSION JOINT	— COPING	
	— GAS LINE	○ OVERFLOW DRAIN	
	— GUTTER	□ ROUND HOOD	
	∧ DOOR	□ EXHAUST FAN	
	● ROOF DRAIN		

Structure Inc.
 Total Building Envelope Management Solutions
 4777 Campus Drive • Kalamazoo, MI 49008
 1121 Lake Cook Road, Ste C • Deerfield, IL 60015
 473 Airport Road, Ste 1 • Butler, PA 18002
 34119 W. Twelve Mile Road, Ste 270 • Farmington Hills, MI 48331

ROOF AREA DESIGNATION PLAN
 2019 ROOF ASSET MANAGEMENT PROGRAM
 CONANT ELEMENTARY - PRE-SCHOOL
 4100 QUARTON RD. BLOOMFIELD HILLS, MI 48302

REVISIONS / ADDENDAS	
SCALE	N.T.S.
APPROVED BY:	H.W.P.
DRAWN BY:	R.A.L.F.
DATE:	AUGUST 2019
PROJECT NUMBER:	T19059
DRAWING NUMBER:	RAMP-07

Structure Inc. KEY OF SYMBOLS

	AREA DESIGNATION		ROOF EDGE
	SLOPE TRANSITION		ROUND HOOD EXHAUST FAN
	COPING		SQUARE HOOD EXHAUST FAN
	GURB, ACTIVE		PENETRATION POCKET
	DRAIN SOFFLER		PIPE PROJECTION
	ROOF DRAIN		
	EXPANSION JOINT		
	GUTTER		
	ROOF HATCH		
	ROOF TOP UNIT		
	SOIL PIPE		
	STACK PROJECTION		

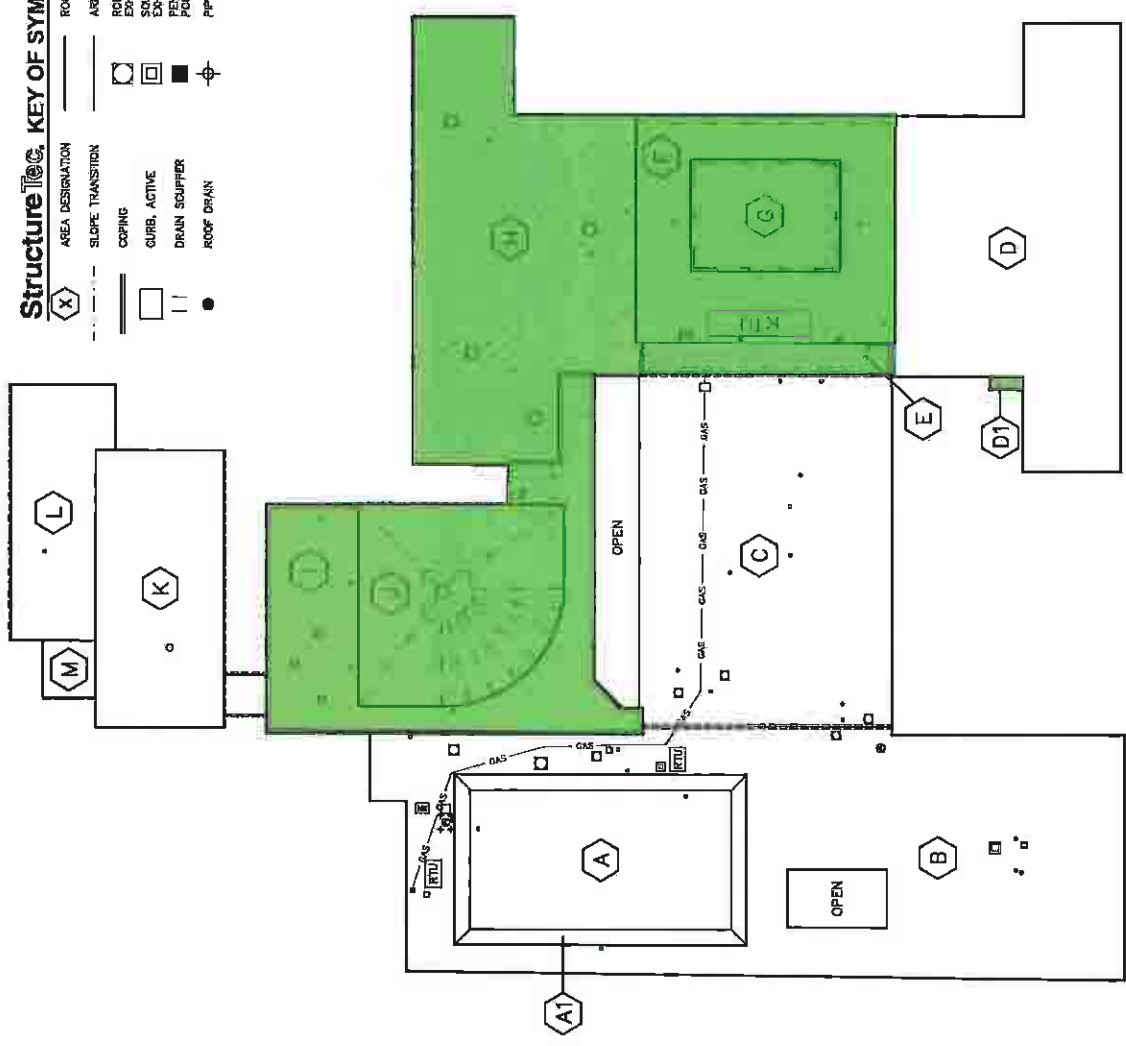



Bloomfield Hills Board of Education

Memo

To: Superintendent and Board of Education
From: Jacob McDermott, Director of Maintenance and Operations
Date: February 24, 2025
Re: Request to Approve Purchase of Wing Lake Developmental Center Playground Upgrades

Recommended Motion:

I move the Board of Education to approve the purchase of new playground equipment and additional soft surface for the Wing Lake Development Center from Snider Recreation, utilizing the OMNIA Cooperative Program, in the amount of \$212,790 and to be paid from the Center Program Fund, as presented.

Background Information:

The board voted that Wing Lake gets new equipment and soft surface for a do not exceed \$250,000 in 2023. Wing Lake reached out to Snider Recreation and this is the design and plan from those meetings. The playground equipment is getting purchased from the Omnia Cooperative program through Snider recreation, as well as the installation of the equipment and soft surface. The project will take place summer of 2025.

ATTACHMENTS:

File Name	Description
WL_Playground-Snider_Recreation.pdf	Wing Lake Playground Upgrades



10139 Royalton Rd Suite K
 N. Royalton, OH 44133
 800-888-2889
www.cvsnyder.com

Date	Quote #
12/31/2024	Q 123124-1REV
WING LAKE	

Name / Address
Wing Lake Developmental Center Jake McDermott 6490 Wing Lake Rd. Bloomfield Hills, MI 48301

PROJECT - SHIP TO
PROJECT: WING LAKE PLAYGROUND ADDITIONS EQUIPMENT DELIVERED ONLY
SHIP TO: TBD

Terms	Rep	Customer Phone	Customer Email	County
Due On Receipt	AH	248-341-7900	Jmcdermott@bloomfield.org	OAKLAND

Item	Description	Qty	Rate	Total
	NEW PLAYGROUND EQUIPMENT			
127-189672-4REV2	127-189672-4REV2 Including Inclusive Orbit, STEMPlay, Panels, music		\$70,012	\$70,012
Freight	Shipping Charges		\$2,100	\$2,100
DISCOUNT	OMNIA DISCOUNT		-\$8,000	-\$8,000
DISCOUNT	BURKE PROGRAM DISCOUNT		-\$2,000	-\$2,000
SHADE	HIP SHADE FOR SWING AREA		\$21,915	\$21,915
SHADE	JOINED SAIL SHADES FOR INCLUSIVE ORBIT AREA		\$49,900	\$49,900
SHADE	HIP SHADE FOR PICNIC AREA 42'X 42'		\$31,250	\$31,250
DISCOUNT	OMNIA DISCOUNT		-\$10,000	-\$10,000
2300 SF	POURED IN PLACE RUBBER FOR INCLUSIVE ORBIT & ORB		\$58,000	\$58,000
DISCOUNT	OMNIA DISCOUNT		-\$8,600	-\$8,600
MISC MATERIALS	STONE BASE FOR RUBBER SURFACE		\$12,000	\$12,000
DISCOUNT	SNIDER PREFERRED CUSTOMER DISCOUNT		-\$3,787	-\$3,787

TERMS	SUBTOTAL	TOTAL
1/2 down with order, balance upon completion with approved credit. If tax exempt certificate is not provided, appropriate sales tax will be charged. Quote is valid for 30 days. Acceptance of this quote assumes acceptance of current Snider Insurance. Freight is subject to surcharge. Payment via credit card will incur an additional 3% Administrative fee.	\$212,790	\$212,790
	TAX	N/A
	TOTAL	\$212,790

IMPORTANT NOTE	QUOTED BY
"Shipping lead times between April and November can run up to 12 weeks. Installation scheduling is on a first-come/first served basis. If you have a deadline, please provide that information with the order. Our goal is to complete every installation in a timely manner, but labor, freight and supply chain issues continue to impact schedules. We ask that you take these things into consideration when placing your order."	VCRAWFORD SNIDER RECREATION, INC.
	ACCEPTED BY _____
	SIGNATURE _____
	DATE _____



10139 Royalton Rd Suite K
 N. Royalton, OH 44133
 800-888-2889
www.cvsnyder.com

Date	Quote #
1/1/2025	Q010125-1REV
WING LAKE	

Name / Address
Wing Lake Developmental Center Jake McDermott 6490 Wing Lake Rd. Bloomfield Hills, MI 48301

PROJECT - SHIP TO
PROJECT: WING LAKE PLAYGROUND ADDITIONS LABOR TO INSTALL EQUIPMENT ONLY
SHIP TO: TBD

Terms	Rep	Customer Phone	Customer Email	County
Due On Receipt	AH	248-341-7900	jmcdermott@bloomfield.org	OAKLAND

Item	Description	Qty	Rate	Total
MBE/LABOR	LABOR TO INSTALL ALL* PLAY EQUIPMENT, SHADES INCLUDING SITE WORK NEEDED * To be Installed Orbit inclusive whirl Panels with stem play Music stations Site prep	1	\$29,500	\$29,500

TERMS 1/2 down with order, balance upon completion with approved credit. If tax exempt certificate is not provided, appropriate sales tax will be charged. Quote is valid for 30 days. Acceptance of this quote assumes acceptance of current Snider Insurance. Freight is subject to surcharge. Payment via credit card will incur an additional 3% Administrative fee.	SUBTOTAL	\$29,500
	TAX	N/A
	TOTAL	\$29,500

IMPORTANT NOTE "Shipping lead times between April and November can run up to 12 weeks. Installation scheduling is on a first-come/first served basis. If you have a deadline, please provide that information with the order. Our goal is to complete every installation in a timely manner, but labor, freight and supply chain issues continue to impact schedules. We ask that you take these things into consideration when placing your order."	QUOTED BY VCRAWFORD SNIDER RECREATION, INC.
	ACCEPTED BY _____
	SIGNATURE _____
	DATE _____



PLAYGROUNDS

186 Brockard Road
Mars, Pa 15046
-1724434441
crystal@bearofpa.com

Estimate

ESTIMATE#	1910
DATE	01/22/2025
PO#	

CUSTOMER

Wing Lake Developmental Center
6490 Wing Lake Road
Bloomfield Hills MI 48301
Jake McDermott
(248) 341-7900
jmcdermott@bloomfield.org

SERVICE LOCATION

6490 Wing Lake Road
Bloomfield Hills MI 48301

DESCRIPTION

Estimate

Description	Qty	Rate	Total
Installation of Shade, Orb Spinner, SternPlay Panels & Outdoor Multi-Use Structures by BCI Burke - Price Includes labor, concrete, mobilization, overnight accommodation	1.00	32,847.00	32,847.00
PA Sales Tax		6.50%	0.00

Estimate Total:

\$32,847.00

CUSTOMER MESSAGE

Quote is valid for 30 days or sale end date.
50% Down; Balance upon completion.

PRE-WORK SIGNATURE

Signature line for Pre-Work Signature

Signed By:

Signed By signature line

MITCH BURLEY ENTERPRISES

11342 N, SAGINAW
 CLIO, MI 48420
 810-577-4728

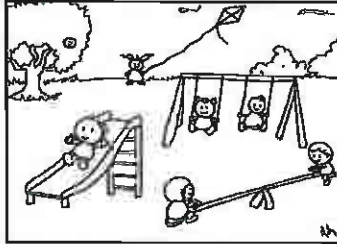

DATE: January 21, 2025
 QUOTE # QUO_202501

Bill To:

Bloomfield Hills Schools
 Attn: Jake McDermott
jmcdermott@

Ship To:

TBD

PROJECT

Wing Lake Playground Installation

QUANTITY	DESCRIPTION	UNIT PRICE	AMOUNT
1	Installation to manufacturer specifications - BCI Burke equipment		\$ 32,600.00
	Assumes equipment is onsite and ready to be installed		
	Includes ground preparation and concrete footings		
	Pricing is labor only and does not include any equipment		

NOTES:	SUBTOTAL	\$ 32,600.00
	TOTAL	\$ 32,600.00

QUOTED BY: MITCH BURLEY

ACCEPTED BY _____ DATE _____

THANK YOU FOR YOUR BUSINESS!

PROPOSAL # 127-18972-5

WING LAKE DEVELOPMENT CENTER OPTION 3

Burke
PLAY THAT MOVES YOU!
SANDUSKI, ONTARIO • 800.251.6260



3D Designer: Sam



WING LAKE DEVELOPMENT CENTER OPTION 3

PROPOSAL # 127-18967-5



STEAMPUNK NEWTON

STEAMPUNK BLECTION

INCLUSIVE ORBIT

PLAY ENSEMBLE TITAN CHIMES

ORB ROCKER

STEAMPUNK MOMENTUM

STEAMPUNK GRAVITY

PROPOSAL # 117-181071-3

WING LAKE DEVELOPMENT CENTER OPTION 3

Burke
PLAY THAT MOVES YOU!
RECREATION • EDUCATION



3D Designer: Sam

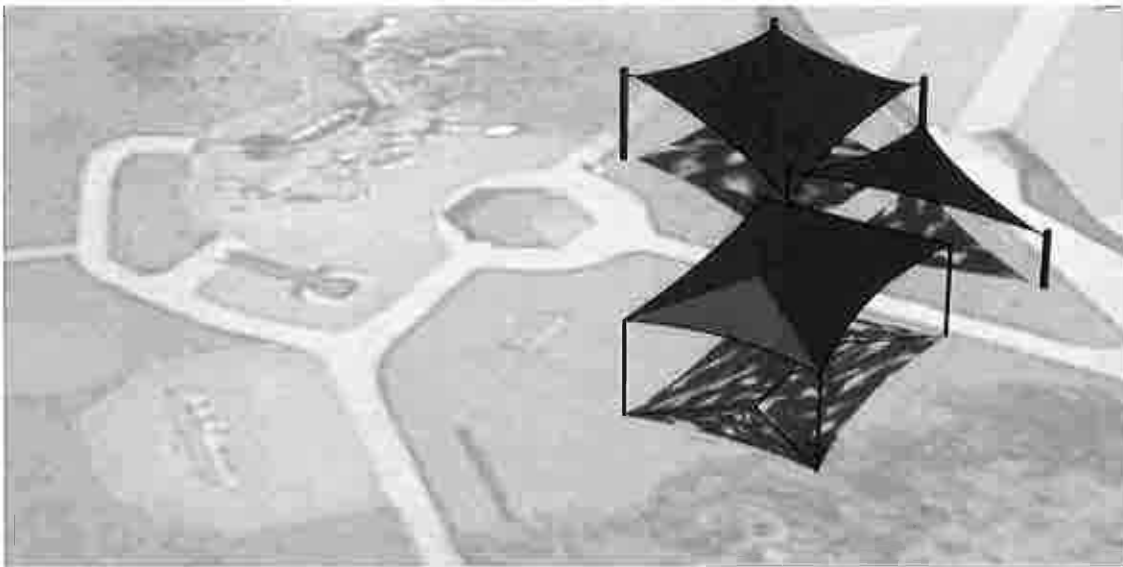

October 03, 2024

Jake McDermott
Bloomfield Hills Schools
7273 Wing Lake Rd
Bloomfield Township, MI 48301

Dear Jake McDermott:

Snider Recreation, Inc. is delighted to provide Bloomfield Hills Schools with this playground equipment proposal.

This design was developed with your specific needs in mind, and we look forward to discussing this project further with you to ensure your complete satisfaction. Snider Recreation, Inc. is confident that this proposal will satisfy Bloomfield Hills Schools's functional, environmental, and safety requirements - and most importantly -- bring joy and excitement to the children and families directly benefiting from your new playground.

You have our personal commitment to support this project and your organization in every manner possible, and we look forward to developing a long-standing relationship with Bloomfield Hills Schools. We appreciate your consideration and value this opportunity to earn your business.

Sincerely,

Vicki Crawford
Sales Representative

Snider Recreation, Inc.
10139 Royalton Road Suite K
North Royalton, OH 44133
www.cvsnider.com
www.bciburke.com

Phone: 440-877-9151
Fax: 440-877-9159
vcrawford@cvsnider.com



COOPERATIVE PURCHASING OPTIONS

PLAYGROUNDS WITHOUT ALL THE PAPERWORK

Purchasing with contracts may sound intimidating, but getting your community playspace doesn't need to be a painful process of writing specifications, issuing RFP's and jumping through hoops – it can be simplified – we promise! As you continue planning for your new playground, review the Purchasing Contracts offered through our partners.

EQUALIS GROUP

Equalis is an innovative cooperative purchasing organization that believes in the power of partnership and that when you work together you achieve more. The basic premise of the Equalis cooperative purchasing organization is to leverage the combined buying power of all members for better pricing and favorable contract terms. Equalis Group uses the lead agency model for competitively bid contracts, provides our participants the savings they expect and offers efficiencies and peace of mind within the procurement process. It is our mission to continuously improve the measurable and meaningful impact of cooperative services for everyone throughout the supply chain.

GOVMVMT

GOVMVMT is a non-profit group purchasing organization that meets the highest industry standards while putting the public's interest at the forefront of everything they do. Each one of GOVMVMT's first-class suppliers has consciously joined their mission to create the most credible, ethical, and public agency-focused non-profit cooperative purchasing program in the country.

GSA

Federal parks, child development programs, military bases and other agencies are a major priority for BCI Burke, and agencies can purchase Burke playgrounds through Burke's GSA contract for installation virtually anywhere in the world.

OMNIA PARTNERS

OMNIA Partners, Public Sector (Subsidiary National IPA) is the largest and most experienced organization in purchasing and supply chain management. Comprised of participants and suppliers in the public sector, we bring together industry-leading buying power and world-class suppliers to offer an extensive portfolio of competitively solicited and publicly awarded contracts and partnerships. OMNIA Partners is proud to offer more value and resources to state and local government, higher education, K-12 education and non-profits.

SOURCEWELL

As a leader in cooperative purchasing, Sourcewell is passionate about helping members fulfill their public service missions. Sourcewell builds strong relationships with members and vendors to develop practical solutions together.

The easiest way to Join Our Movement is to call your local Representative at 800.266.1250 or visit bciburke.com/rep. Our passion is bringing play to communities like yours and we can't wait to help you get started!



BCIBURKE.COM

Burke

800.266.1250

DESIGN SUMMARY

Snider Recreation, Inc. is very pleased to present this Proposal for consideration for the Wing Lake Developmental Center located in Bloomfield Township. BCI Burke Company, LLC has been providing recreational playground equipment for over 100 years and has developed the right mix of world-class capabilities to meet the initial and continuing needs of Bloomfield Hills Schools. We believe our proposal will meet or exceed your project's requirements and will deliver the greatest value to you.

The following is a summary of some of the key elements of our Proposal:

- Project Name: Wing Lake Developmental Center
- Project Number: 127-189672-5
- User Capacity: 50
- Age Groups: 5 to 12, 13Plus
- Dimensions: 54' 4"x35' 9"
- Designer Name: Lee Olig

Snider Recreation, Inc. has developed a custom playground configuration based on the requirements as they have been presented for the Wing Lake Developmental Center playground project. Our custom design will provide a safe and affordable playground environment that is aesthetically pleasing, full of fun for all users and uniquely satisfies your specific requirements. In addition, proposal # 127-189672-5 has been designed with a focus on safety, and is fully compliant with ASTM F1487 and CPSC playground safety standards.

We invite you to review this proposal for the Wing Lake Developmental Center playground project and to contact us with any questions that you may have.

Thank you in advance for giving us the opportunity to make this project a success.



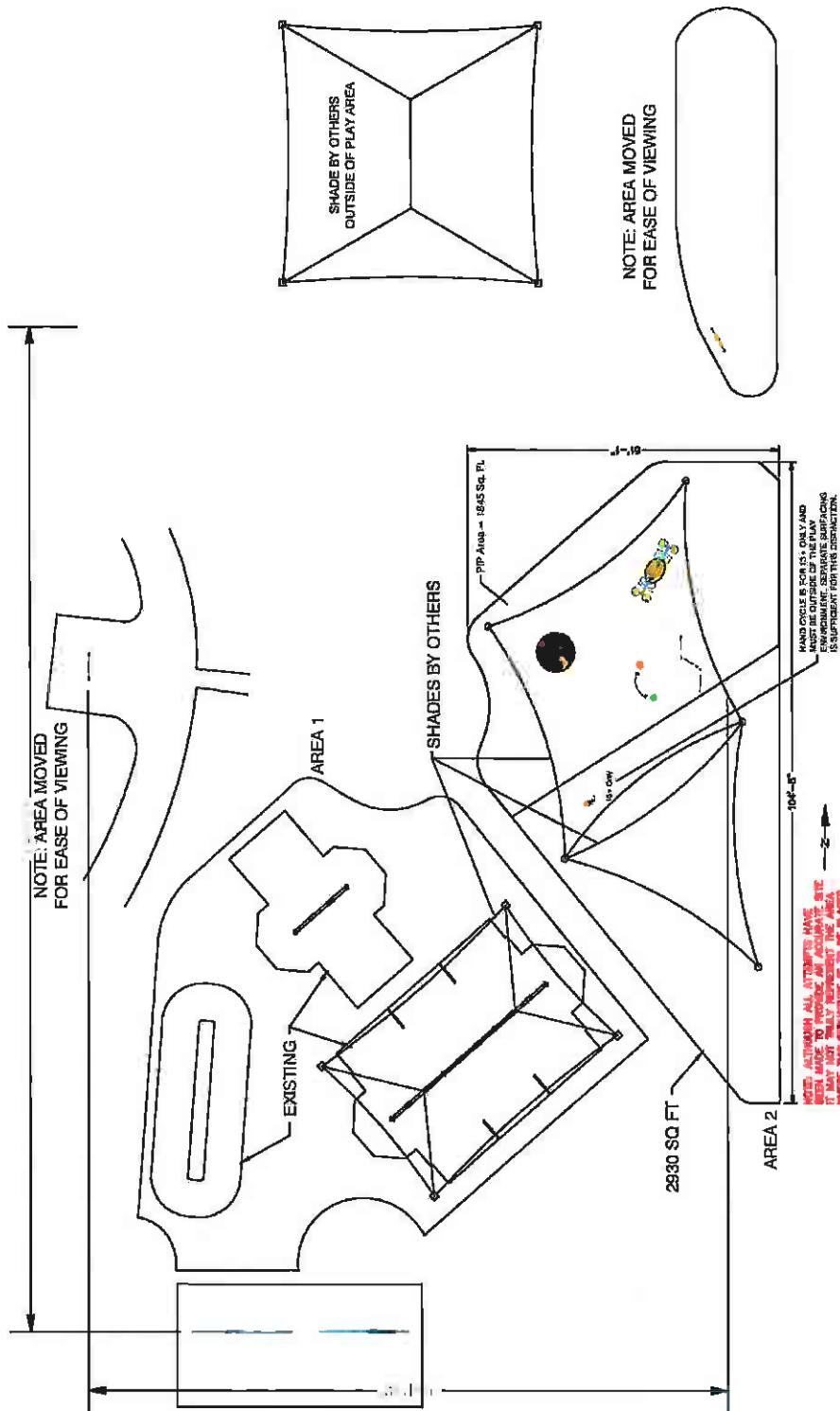

PLAYGROUND ACCESSIBILITY (Provided/Required)			
TOTAL ELEVATED EVENTS	TRANSFER ACCESSIBLE	RAMP ACCESSIBLE	GROUND EVENTS
15	0 / 0	0 / 0	15 / 0
			6 / 0

OVERALL BOUNDING OF USE ZONES **The space requirements shown here are to ASTM standards. Requirements for other standards may be different.

Area: 17'114.8 sq. ft.
 Perimeter: 536.4 ft.
 STRUCTURE SIZE#1: 8'x163' 7"
 POST SIZE(\$): 2.375"

The use and layout of play components identified in this plan conform to the CPSC guidelines. U.S. CPSC recommends the separation of age groups in playground layouts.

SERIES Nucleus | Burke Basics | Fitness

SITE PLAN VIEW

GROUP:
 FS Panels|StemPlay|PlayEnsemble|Sound Garden|Fitness|Freestanding

DESIGNED FOR AGES:
 5 to 12, 13+

Wing Lake Developmental Center
 Bloomfield Township, MI 48301-1538

10/03/2024

Snider Recreation, Inc.

127-189672-5

Designer: Lee Olig



Warning: Accessible safety surfacing material is required beneath and around this equipment, that is compliant with ASTM, CPSC, and ADAAG requirements.

ITEM	COMP.	DESCRIPTION
1	560-1703	STEMPLAY SHORT ACTIVITY FRAME
2	560-2685	STEMPLAY MOMENTUM
3	560-2689	STEMPLAY GRAVITY
4	560-1701	STEMPLAY TALL ACTIVITY FRAME
5	560-2691	STEMPLAY ELECTRON
6	560-2686	STEMPLAY NEWTON

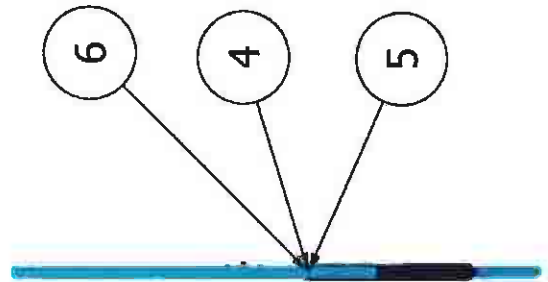
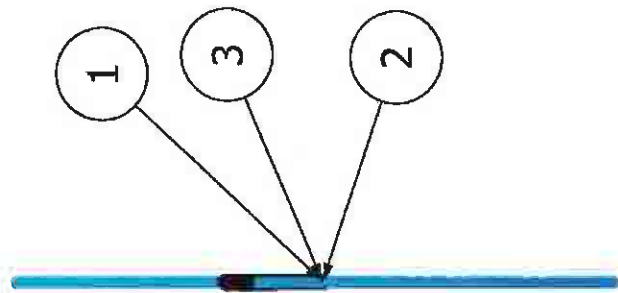

SERIES Burke Basics		COMPONENT VIEW	
GROUP: StemPlay	Wing Lake Developmental Center Bloomfield Township, MI 48301-1538		10/03/2024
DESIGNED FOR AGES: 5 to 12			Snider Recreation, Inc. 127-189672-5
			Designer: Lee Olig
BCI BURKE COMPANY, LLC PO BOX 549 FOND DU LAC, WI 54936-0549 920.921.9220 BCI BURKE.COM			

ITEM	COMP.	DESCRIPTION
1	570-0410	PLAYENSEMBLE TITAN CHIMES
2	560-0055	PLAYENSEMBLE CIRQUE DRUM V
3	560-0056	PLAYENSEMBLE CIRQUE DRUM IV

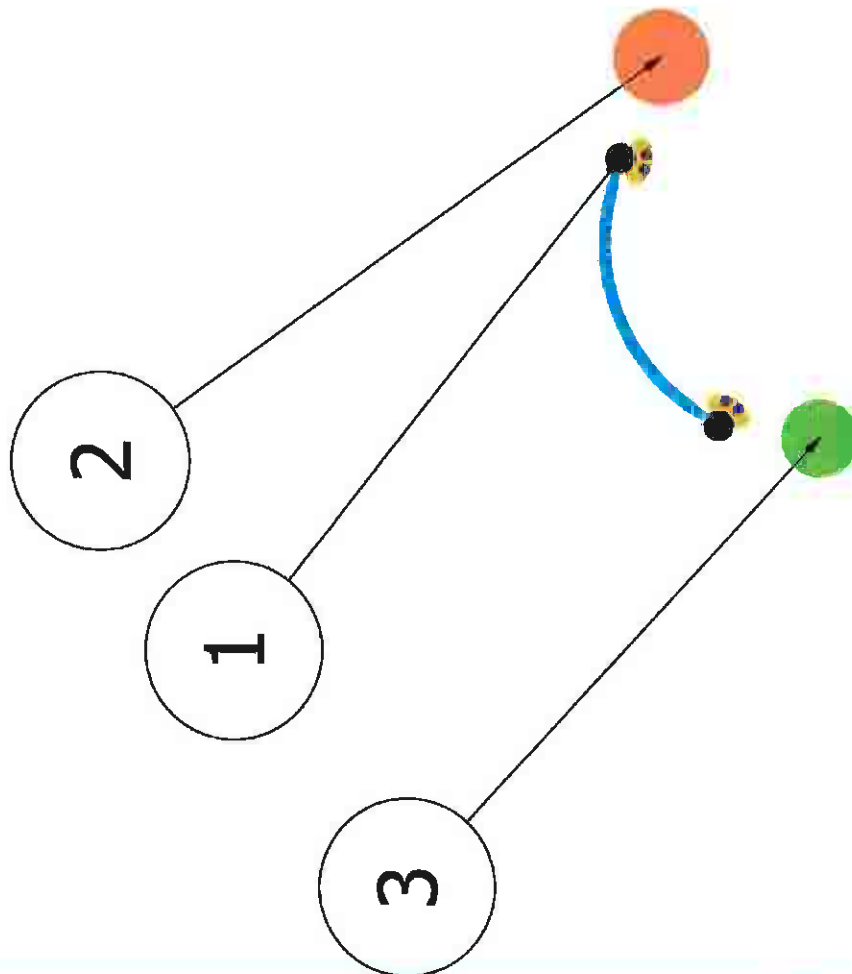

SERIES Nucleus Burke-Basles	COMPONENT VIEW	
GROUP: PlayEnsemble	Wing Lake Developmental Center Bloomfield Township, MI 48301-1538	10/03/2024
DESIGNED FOR AGES: 5 to 12	Burke PLAY THAT MOVES YOU.	Snider Recreation, Inc. 127-189672-5 Designer: Lee Olig
<small>EQI BURKE COMPANY, LLC PO BOX 549 FOND DU LAC, WI 54936-0549 920.921.9220 DC@BURKE.COM</small>		

ITEM	COMP.	DESCRIPTION
1	580-0324	TOUCH & PLAY PIANO ELEMENT
2	580-0232	GUITAR ELEMENT
3	580-0325	TOUCH & PLAY DRUM ELEMENT

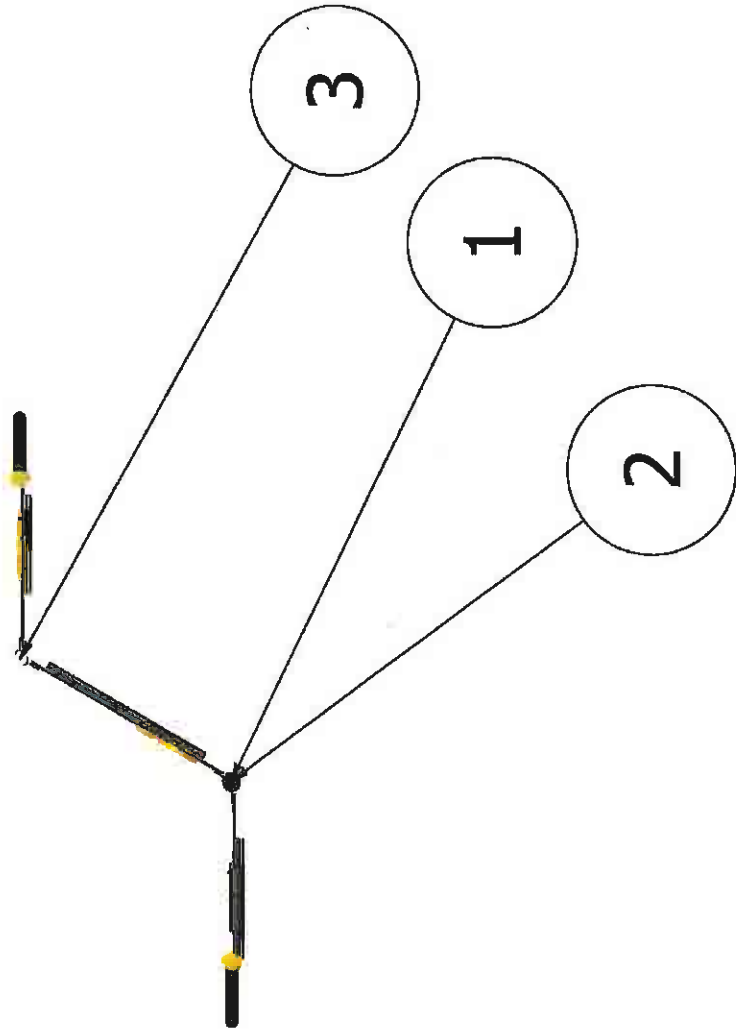

SERIES Burke Basics	COMPONENT VIEW	
GROUP: Sound Garden	Wing Lake Developmental Center Bloomfield Township, MI 48301-1538	10/03/2024
DESIGNED FOR AGES: 13+	Burke PLAY THAT MOVES YOU	Snider Recreation, Inc. 127-189672-5 Designer: Lee Olig
BCI BURKE COMPANY, L.L.C. PO BOX 549 FOND DU LAC, WI 54936-0549 920.921.9220 BCI BURKE.COM		

ITEM	COMP.	DESCRIPTION
1	570-2730	INVIGORATE HAND CYCLE

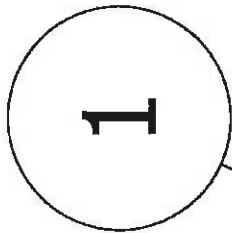

SERIES Fitness	COMPONENT VIEW	
GROUP: Fitness	Wing Lake Developmental Center Bloomfield Township, MI 48301-1538	10/03/2024
DESIGNED FOR AGES: 5 to 12	Burke PLAY THAT MOVES YOU.	Snider Recreation, Inc. 127-189672-5 Designer: Lee Olig
BCI BURKE COMPANY, LLC PO BOX 549 FOND DU LAC, WI 54936-0549 320 921 9220 BCIBURKE.COM		

ITEM	COMP.	DESCRIPTION
1	560-0051	INCLUSIVE ORBIT
2	570-2745	ORB ROCKER
3	570-2727	ORB ROCKER FOOTER

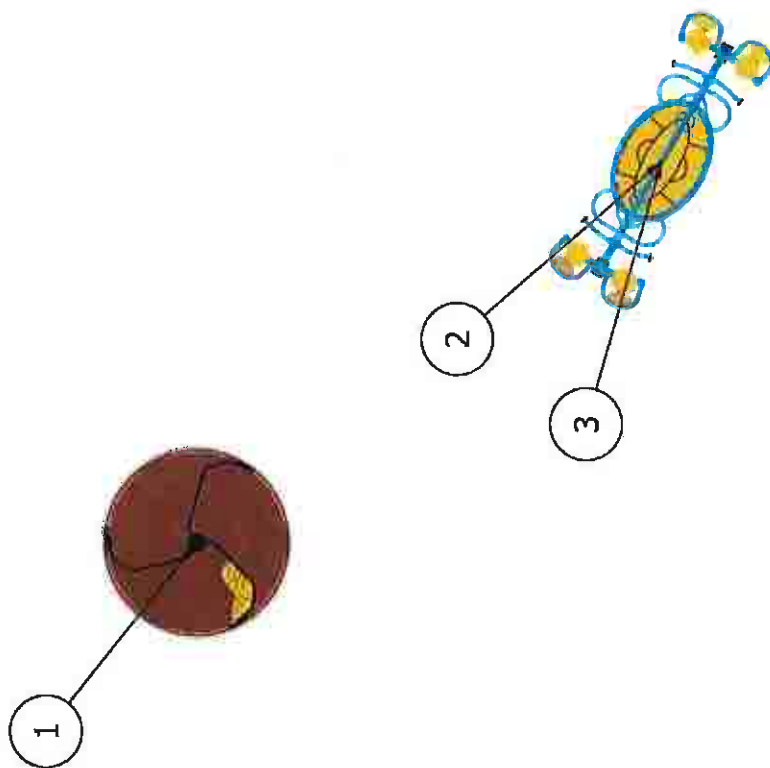

SERIES Burke Basics	COMPONENT VIEW	
GROUP: Freestanding	Wing Lake Developmental Center Bloomfield Township, MI 48301-1538	10/03/2024
DESIGNED FOR AGES: 5 to 12	Burke PLAY THAT MOVES YOU	Snider Recreation, Inc. 127-189672-5 Designer: Lee Olig
BCI BURKE COMPANY, LLC PO BOX 549 FOND DU LAC, WI 54936-0549 920-921-9220 BCI@BURKE.COM		

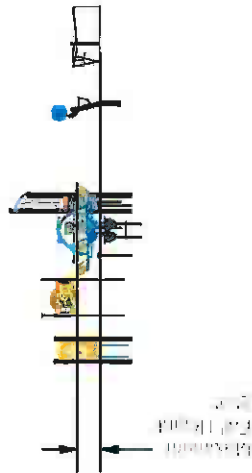
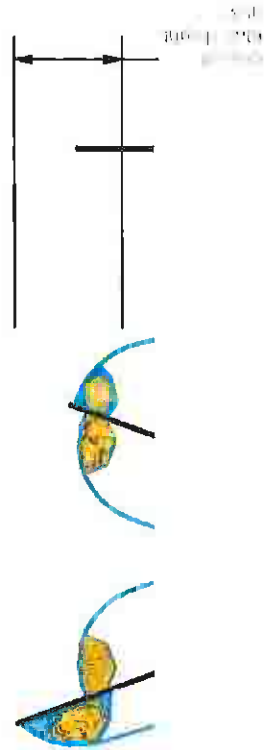

SERIES Nucleus Burke Basics Fitness	ELEVATION VIEW
GROUP: FS Panels StemPlay PlayEnsemble Sound Garden Fitness Freeslandng DESIGNED FOR AGES: 5 to 12, 13+	Wing Lake Developmental Center Bloomfield Township, MI 48301-1538 
10/03/2024 Snider Recreation, Inc. 127-189672-5 Designer: Lee Olig	
<small>BOI BURKE COMPANY, LLC PO BOX 549 FOND DU LAC, WI 54936-0549 920.921.9220 RC BURKE.COM</small>	

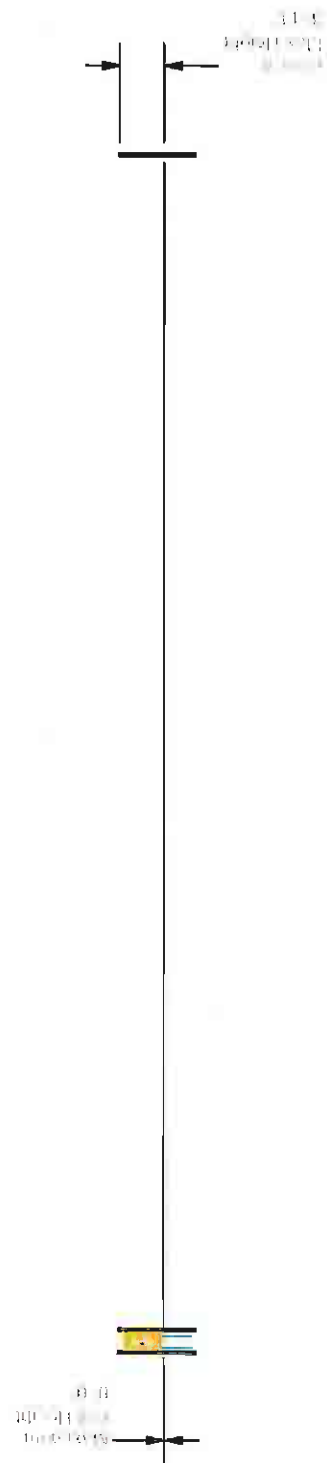

SERIES Nucleus	ELEVATION VIEW	
GROUP: FS Panels	Wing Lake Developmental Center Bloomfield Township, MI 48301-1538	10/03/2024
DESIGNED FOR AGES: 5 to 12	Burke PLAY THAT MOVES YOU	Snider Recreation, Inc. 127-189672-5
BCI BURKE COMPANY, LLC PO BOX 549 FOND DU LAC, WI 74935-0549 920 921 9220 BCI BURKE.COM		

Designer: Lee Olig

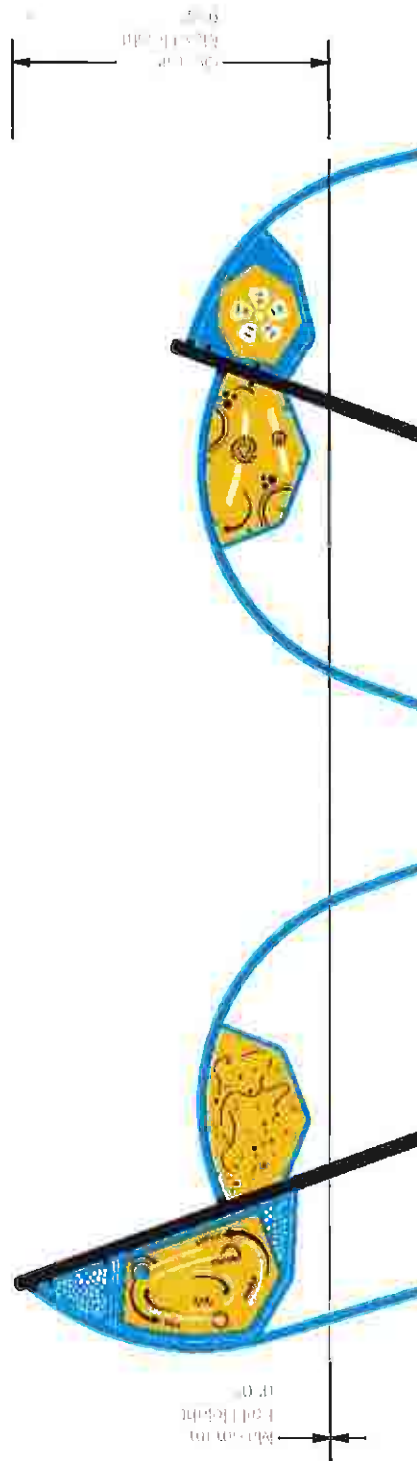

<p>SERIES Burke Basics</p>		<p>ELEVATION VIEW</p>
<p>GROUP: StemPlay</p>	<p>Wing Lake Developmental Center Bloomfield Township, MI 48301-1538</p>	<p>10/03/2024</p>
<p>DESIGNED FOR AGES: 5 to 12</p>	<p>Burke PLAY THAT MOVES YOU</p>	<p>Snider Recreation, Inc. 127-189672-5 Designer: Lee Olig</p>
<p>BCI BURKE COMPANY, LLC P.O. BOX 549 FOND DU LAC, WI 54936-0549 920 921 9220 BCIBURKE.COM</p>		

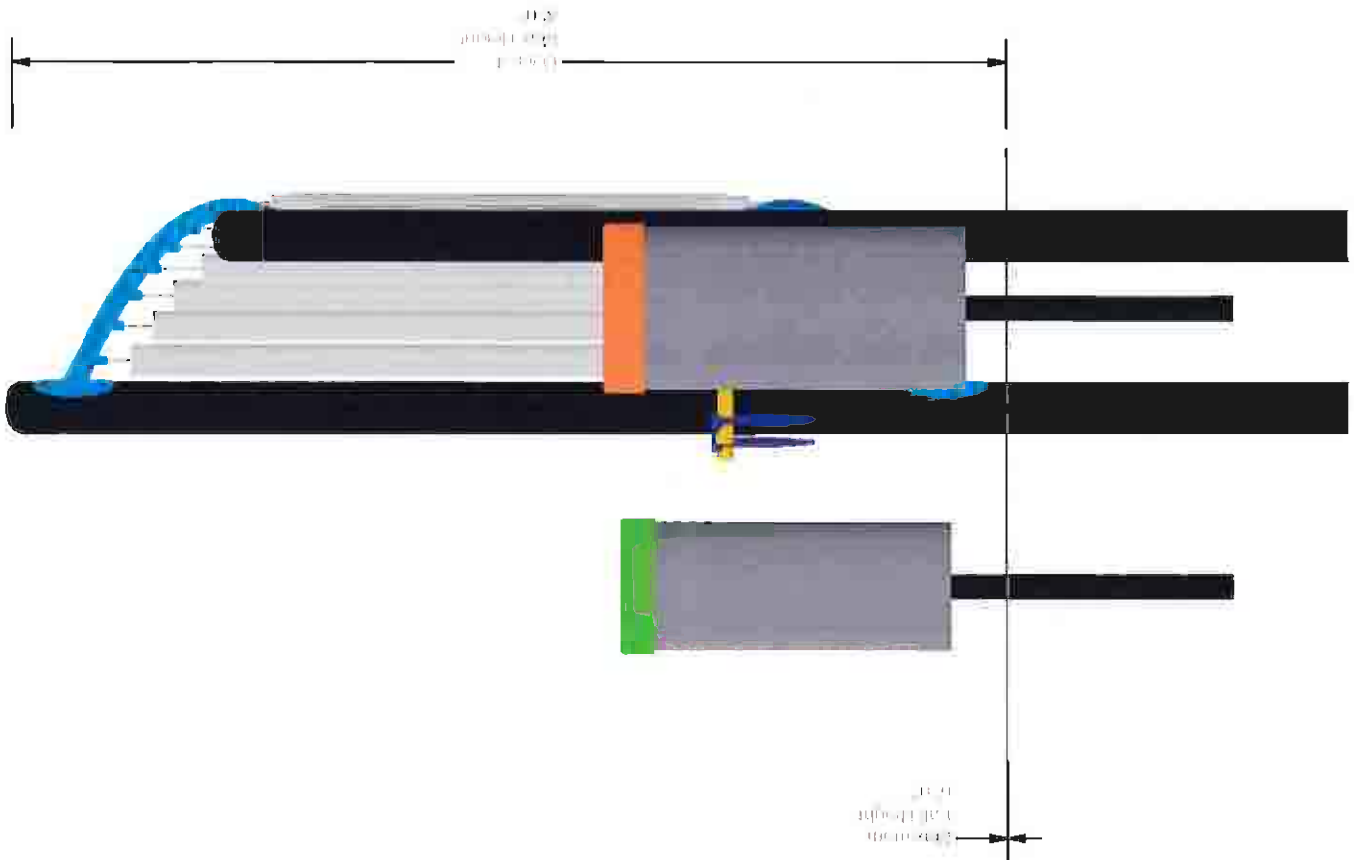

SERIES Nucleus Burke Basics	Wing Lake Developmental Center Bloomfield Township, MI 48301-1538	ELEVATION VIEW
GROUP: PlayEnsemble		10/03/2024
DESIGNED FOR AGES: 5 to 12		Snider Recreation, Inc. 127-189672-5 Designer: Lee Olig
BCI BURKE COMPANY, LLC PO BOX 549 FOND DU LAC, WI 54936-0549 920 921 9220 BCIBURKE.COM		

2'-0"
11/19/2024
11/20/2024



2'-0"
11/19/2024
11/20/2024

SERIES Burke Basics		ELEVATION VIEW
GROUP: Sound Garden	Wing Lake Developmental Center Bloomfield Township, MI 48301-1538	10/03/2024
DESIGNED FOR AGES: 13+	Burke PLAY THAT MOVES YOU	Snider Recreation, Inc. 127-189672-5 Designer: Lee Olig
BCI BURKE COMPANY, LLC PO BOX 549 FOND DU LAC, WI 54936-0549 920.921.9220 BCI.BURKE.COM		



SERIES Fitness		ELEVATION VIEW
GROUP: Fitness	Wing Lake Developmental Center Bloomfield Township, MI 48301-1538	10/03/2024 Snider Recreation, Inc.
DESIGNED FOR AGES: 5 to 12	Burke. PLAY THAT MOVES YOU.	127-189672-5 Designer: Lee Ollg
BCI BURKE COMPANY, LLC PO BOX 549 FOND DU LAC, WI 54935-0549 920 921 9220 BCIBURKE.COM		

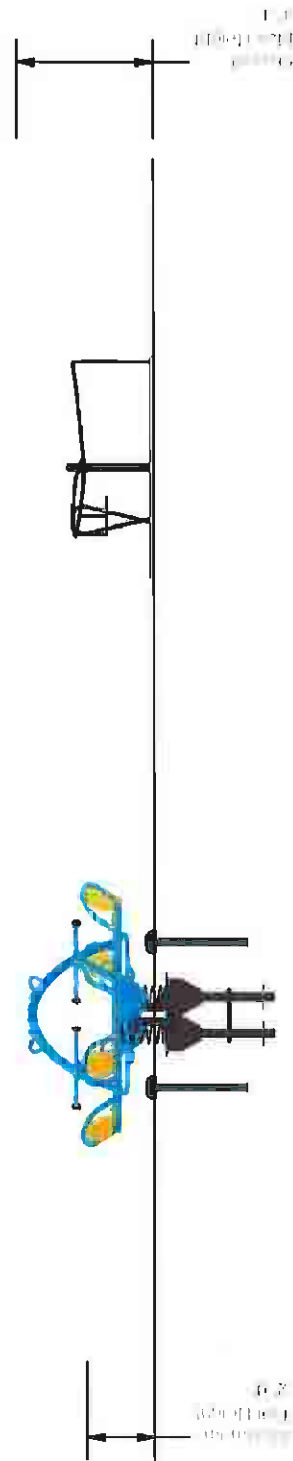

SERIES Burke Basics	ELEVATION VIEW
GROUP: Freestanding	Wing Lake Developmental Center Bloomfield Township, MI 48301-1538
DESIGNED FOR AGES: 5 to 12	10/03/2024 Snider Recreation, Inc. 127-189672-5 Designer: Lee Olig
<div style="text-align: center;">  </div>	
BCI BURKE COMPANY, LLC PO BOX 549 FOND DU LAC, WI 54936-0549 920.921.9220 BCIBURKE.COM	



SERIES Nucleus Burke Basics Fitness	Wing Lake Developmental Center Bloomfield Township, MI 48301-1538	ISOMETRIC VIEW
GROUP: FS Panels StemPlay PlayEnsemble Sound Garden Fitness Freestanding DESIGNED FOR AGES: 5 to 12, 13+		10/03/2024 Snider Recreation, Inc. 127-189672-5 Designer: Lee Olig
<p style="text-align: center;">Burke PLAY THAT MOVES YOU</p> <p style="text-align: center;"><small>BCI BURKE COMPANY, LLC PO BOX 549 FOND DU LAC, WI 54936-0549 920 921 9220 BCIBURKE.COM</small></p>		



SERIES	Nucleus	ISOMETRIC VIEW
GROUP: FS Panels	Wing Lake Developmental Center Bloomfield Township, MI 48301-1538	10/03/2024 Snider Recreation, Inc.
DESIGNED FOR AGES: 5 to 12	Burke. PLAY THAT MOVES YOU.	127-189672-5 Designer: Lee Ollg
BCI BURKE COMPANY, LLC PO BOX 549 FOND DU LAC, WI 54936-0549 920.921.9220 BCI BURKE.COM		



<p>SERIES Burke Basics</p>		<p>ISOMETRIC VIEW</p>
<p>GROUP: StemPlay</p>	<p>Wing Lake Developmental Center Bloomfield Township, MI 48301-1538</p>	<p>10/03/2024 Slider Recreation, Inc.</p>
<p>DESIGNED FOR AGES: 5 to 12</p>	<p>Burke PLAY THAT MOVES YOU</p>	<p>127-189672-5 Designer: Lee Olig</p>
<p>BCI BURKE COMPANY, LLC PO BOX 549 FOND DU LAC, WI 54936-0549 920.921.9221 BCI.BURKE.COM</p>		

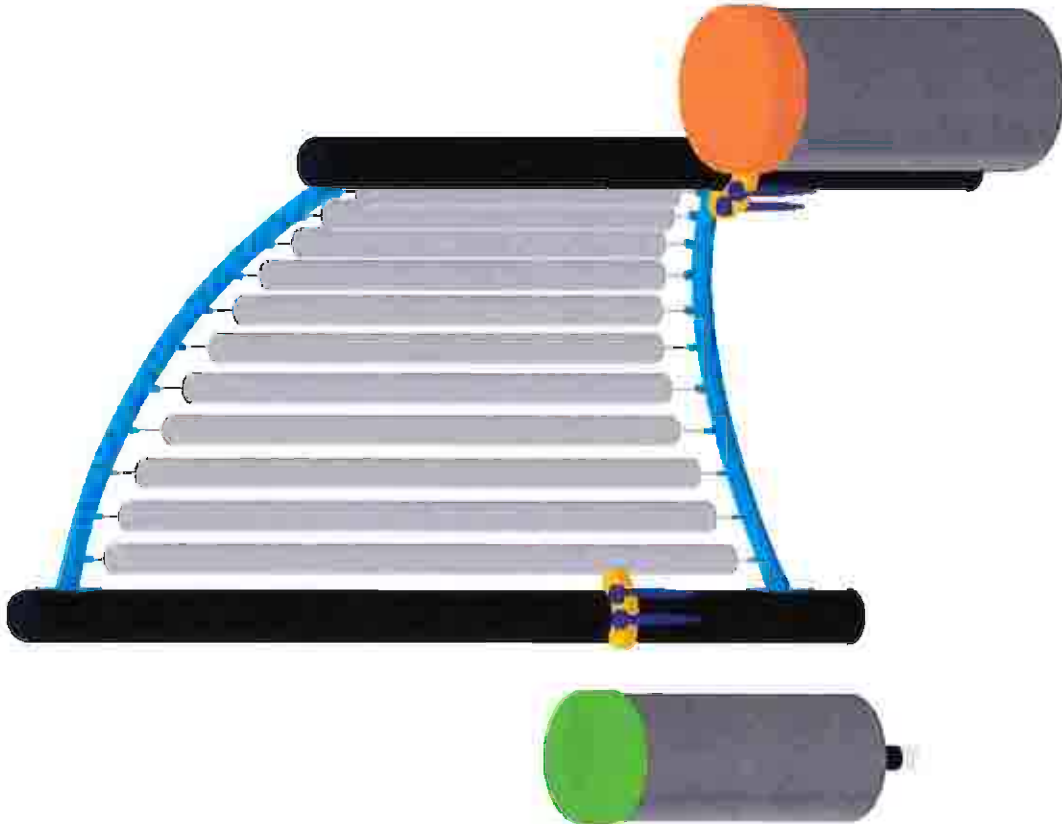

<p>SERIES Nucleus Burke Basics</p>		<p>ISOMETRIC VIEW</p>
<p>GROUP: PlayEnsemble</p>	<p>Wing Lake Developmental Center Bloomfield Township, MI 48301-1538</p>	<p>10/03/2024</p>
<p>DESIGNED FOR AGES: 5 to 12</p>	<p>Burke PLAY THAT MOVES YOU.</p>	<p>Snider Recreation, Inc. 127-189672-5 Designer: Lee Olig</p>
<p>BCI BURKE COMPANY, LLC PO BOX 549 FOND DU LAC, WI 54936-0549 920.921.9220 BCIBURKE.COM</p>		

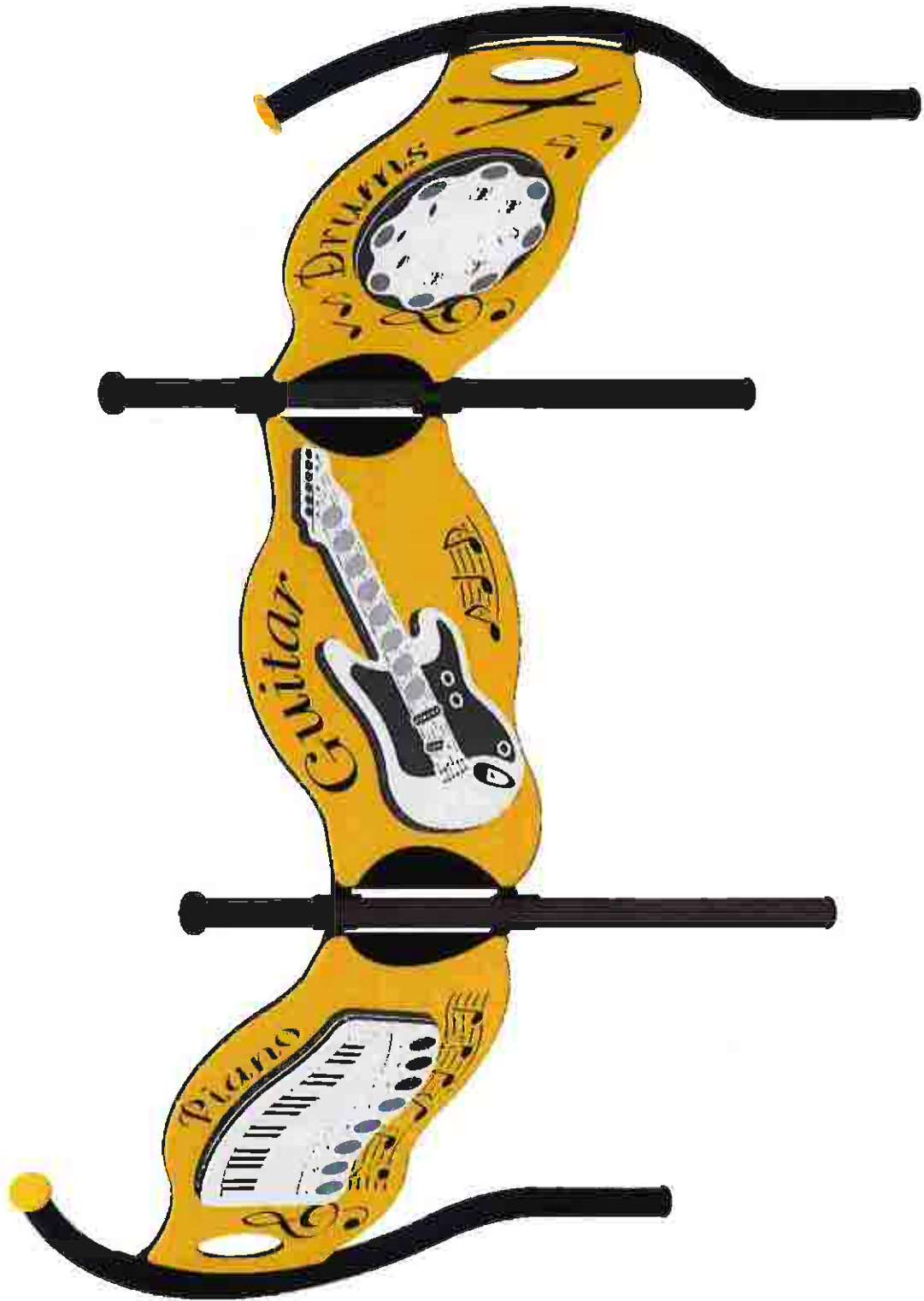

<p>SERIES Burke Basics</p>		<p>ISOMETRIC VIEW</p>
<p>GROUP: Sound Garden</p>	<p>Wing Lake Developmental Center Bloomfield Township, MI 48301-1638</p>	<p>10/03/2024</p>
<p>DESIGNED FOR AGES: 13+</p>	<p>Burke. PLAY THAT MOVES YOU</p>	<p>Snider Recreation, Inc. 127-189672-5 Designer: Lee Ollg</p>
<p>BET BURKE COMPANY, L.L.C. PO BOX 549 FOND DU LAC, WI 54936-0549 920.921.9220 BCIBURKE.COM</p>		



SERIES Fitness		ISOMETRIC VIEW
GROUP: Fitness	Wing Lake Developmental Center Bloomfield Township, MI 48301-1538	10/03/2024
DESIGNED FOR AGES: 5 to 12	Burke PLAY THAT MOVES YOU	Snider Recreation, Inc. 127-189672-5 Designer: Lee Ollg
BCI BURKE COMPANY, LLC PO BOX 549 FOND DU LAC, WI 54936-0549 920.921.9220 BCIBURKE.COM		

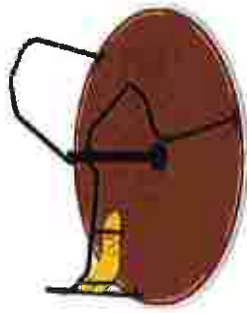

SERIES Burke Basics

ISOMETRIC VIEW

GROUP:
Freestanding

Wing Lake Developmental Center
Bloomfield Township, MI 48301-1538

10/03/2024

DESIGNED FOR AGES:
5 to 12

Snider Recreation, Inc.
127-189672-5

Designer: Lee Olig

Burke
PLAY THAT MOVES YOU

The play components identified in this proposal are IPEMA certified. The use and layout of these components conform to the requirements of ASTM F1487. To verify product certification, visit www.ipema.org.



The space requirements shown in this proposal are to ASTM standards. Requirements for other standards may be different.

Component No.	Description	Qty	User Cap	Ext. User Cap	Weight	Ext. Weight
---------------	-------------	-----	----------	---------------	--------	-------------

FS Panels

Nucleus

072-0500-80C	5" OD X 80" CAPPED POST	4	0	0	42	168
570-2702	COLLISION PANEL, BELOW PLATFORM	1	1	1	55	55
570-2734	CLASSIC GAME PANEL, BELOW	1	2	2	65	65
660-0103	MAINTENANCE KIT, STRUCTURE	1	0	0	7	7
660-0104	INSTALLATION KIT, STRUCTURE	1	0	0	5	5

Total User Capacity: 3
Total Weight: 300 lbs.

StemPlay

Burke Basics

560-1701	STEMPLAY TALL ACTIVITY FRAME	1	0	0	235	235
560-1703	STEMPLAY SHORT ACTIVITY FRAME	1	0	0	176	176
560-2685	STEMPLAY MOMENTUM	1	4	4	35	35
560-2686	STEMPLAY NEWTON	1	3	3	129	129
560-2689	STEMPLAY GRAVITY	1	2	2	63	63
560-2691	STEMPLAY ELECTRON	1	5	5	91	91
660-0101	INSTALL KIT, BURKE BASICS - P...	1	0	0	2	2

Total User Capacity: 14
Total Weight: 731 lbs.

Sound Garden

Burke Basics

580-0232	GUITAR ELEMENT	1	4	4	38	38
580-0324	TOUCH & PLAY PIANO ELEMENT	1	4	4	59	59
580-0325	TOUCH & PLAY DRUM ELEMENT	1	4	4	56	56
660-0101	INSTALL KIT, BURKE BASICS - P...	1	0	0	2	2
660-0145	POST ASSEMBLY 2 3/8" OD X 85 ...	2	0	0	19	38

Total User Capacity: 12

Total Weight: 193 lbs.

Freestanding

Burke Basics

560-0051	INCLUSIVE ORBIT	1	6	6	667	667
570-2727	ORB ROCKER FOOTER	1	0	0	93	93
570-2745	ORB ROCKER	1	8	8	540.9	540.9
660-0101	INSTALL KIT, BURKE BASICS - P...	1	0	0	2	2

Total User Capacity: 14
Total Weight: 1303 lbs.

PlayEnsemble

Nucleus

072-0500-108C	5" OD X 108" CAPPED POST	1	0	0	57	57
072-0500-128C	5" OD X 128" CAPPED POST	1	0	0	67	67
570-0410	PLAYENSEMBLE TITAN CHIMES	1	2	2	121	121

PlayEnsemble

Burke Basics

560-0055	PLAYENSEMBLE CIRQUE DRUM V	1	2	2	48	48
560-0056	PLAYENSEMBLE CIRQUE DRUM IV	1	1	1	32	32

Total User Capacity: 5
Total Weight: 325 lbs.

Fitness

Fitness

570-2730	INVIGORATE HAND CYCLE	1	2	2	98	98
----------	-----------------------	---	---	---	----	----

Total User Capacity: 2
Total Weight: 98 lbs.

Special Notes:

Prices do not include freight, unloading, material storage, site excavation/preparation, removal of existing equipment, removal of excess soil from footing holes, site security, safety surfacing, installation, or sales tax (if applicable). Prices are based on standard colors per CURRENT YEAR BCI Burke Catalog. Custom colors, where available, would be an extra charge. **Pricing is valid for 30 days from the date of this proposal.**

COLOR SELECTION LIST | Default Color Option

GROUP 1 (FS Panels)

Post: Navy
Acc: Sky
Flat: Yellow
Panel: Yellow-Black-Yellow
Plastic: Yellow

GROUP 2 (StemPlay)

Post: Navy
Acc: Sky
Panel: Yellow-Black-Yellow
Flat: Yellow

GROUP 3 (PlayEnsemble)

Flat: Yellow
Acc: Sky
Post: Navy

GROUP 4 (Sound Garden)

Flat: Yellow
Panel: Yellow-Black-Yellow
Post: Navy

GROUP 5 (Fitness)

Post: Navy
Acc: Sky
Panel: Yellow-Black-Yellow

GROUP 6 (Freestanding)

Post: Navy
Panel: Yellow-Black-Yellow
Flat: Yellow
Acc: Sky

COLORS THAT MOVE YOU

POWDER COAT PAINT



PLATFORMS



Blue Brown Gray

SOLIS HUE TOPPERS



Green Purple Orange

TRADITIONAL SERIES SITE AMENITIES



Green Blue Red Tan Brown Black Gray

ROCKIT CLIMBERS



Granite Sandstone

HDPE PLASTIC PANELS



Green/Tan Olive/Black Lime/Black Ocean/Black Blue/White Blue/Yellow Purple/Gray
Green Single-Color Olive Single-Color Lime Single-Color Ocean Single-Color Blue Single-Color Blue Single-Color Purple Single-Color

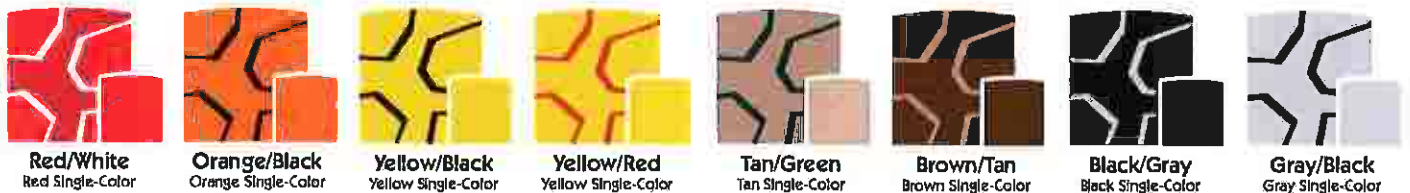

Red/White Orange/Black Yellow/Black Yellow/Red Tan/Green Brown/Tan Black/Gray Gray/Black
Red Single-Color Orange Single-Color Yellow Single-Color Yellow Single-Color Tan Single-Color Brown Single-Color Black Single-Color Gray Single-Color

SHADE CANOPIES



Green Aqua Blue Red Orange Gray Charcoal Lime Sky Purple Mahogany Yellow Sand Brown

ROTOMOLD PLASTIC



Green Olive Lime Ocean Blue Purple Red Orange Yellow Tan Granite

VISIT BCIBURKE.COM/COLOR TO CUSTOMIZE YOUR PLAYGROUND COLORS!

BCIBURKE.COM

Burke

800.266.1250

BURKE GENERATIONS WARRANTY®

BCI Burke Company, LLC ("Burke") warrants that all standard products are warranted to be free from defects in materials and workmanship, under normal use and service, for a period of one (1) year from the date of shipment.

We stand behind our products.

In addition, the following products are warranted, under normal use and service from the date of shipment as follows:

- One Hundred (100) Year Limited Warranty on aluminum and steel upright posts (including Nucleus®, Nucleus Evolution®, Nucleus Aspire™, Intensity®, Level X®, Synergy®, Synergy Imagination® & 4Me® against structural failure due to corrosion, deterioration or workmanship.
- One Hundred (100) Year Limited Warranty on KoreKnect® clamps against structural failure due to corrosion, deterioration or workmanship.
- One Hundred (100) Year Limited Warranty on Hardware (nuts, bolts, washers)
- One Hundred (100) Year Limited Warranty on bolt-through fastening and clamp systems (Synergy®, Intensity®, Nucleus®).
- Twenty-Five (25) Year Limited Warranty on spring assemblies and aluminum cast animals.
- Fifteen (15) Year Limited Warranty on structure platforms and decks, metal roofs, table tops, bench tops, railings and barriers against structural failure due to materials or workmanship.
- Fifteen (15) Year Limited Warranty on all plastic components including StoneBorders against structural failure due to materials or workmanship.
- Ten (10) Year Limited Warranty on ShadePlay® Canopies fabric, threads, and cables against degradation, cracking or material breakdown resulting from ultra-violet exposure, natural deterioration or manufacturing defects. This warranty is limited to the design loads as stated in the specifications. natural deterioration or manufacturing defects. This warranty is limited to the design loads as stated in the specifications.
- Ten (10) Year Limited Warranty on NaturePlay® Boulders and GFRC products against structural failure due to natural deterioration or workmanship. Natural wear, which may occur with any concrete product with age, is excluded from this warranty.
- Ten (10) Year Limited Warranty on Full Color Custom Signage against manufacturing defects that cause delamination or degradation of the sign. Full Color Custom Signs also carry a two (2) year warranty against premature fading of the print and graphics on the signs.
- Five (5) Year Limited Warranty on Nucleus®, Intensity®, and RopeVenture® cables against premature wear due to natural deterioration or manufacturing defects. Determination of premature wear will be at the manufacturer's discretion.
- Five (5) Year Limited Warranty on rubber belt material against premature wear due to natural deterioration or manufacturing defects. Determination of premature wear will be at the manufacturer's discretion.
- Five (5) Year Limited Warranty on moving parts, including swing components, against structural failure due to materials or workmanship.
- Five (5) Year Limited Warranty on PlayEnsemble® cables and mallets against defects in materials and workmanship.
- Three (3) Year Limited Warranty on electronic panel speakers, sound chips and circuit boards against electronic failure caused by manufacturing defects.

The warranty stated above is valid only if the equipment is erected in conformity with the layout plan and/or installation instructions furnished by BCI Burke Company, LLC using approved parts, have been maintained and inspected in accordance with BCI Burke Company, LLC Instructions. Burke's liability and your exclusive remedy hereunder will be limited to repair or replacement of those parts found in Burke's reasonable judgment to be defective. Any claim made within the above stated warranty periods must be made promptly after discovery of the defect. A part is covered only for the original warranty period of the applicable part. Replacement parts carry the applicable warranty from the date of shipment of the replacement from Burke. After the expiration of the warranty period, you must pay for all parts, transportation and service charges.

Burke reserves the right to accept or reject any claim in whole or in part. Burke will not accept the return of any product without its prior written approval. Burke will assume transportation charges for shipment of the returned product if it is returned in strict compliance with Burke's written instructions.

THE FOREGOING WARRANTIES ARE EXCLUSIVE AND IN LIEU OF ANY OTHER WARRANTY, EXPRESS OR IMPLIED, INCLUDING BUT NOT LIMITED TO ANY IMPLIED WARRANTY OR MERCHANTABILITY OR FITNESS FOR A PARTICULAR PURPOSE. IF THE FOREGOING DISCLAIMER OF ADDITIONAL WARRANTIES IS NOT GIVEN FULL FORCE AND EFFECT, ANY RESULTING ADDITIONAL WARRANTY SHALL BE LIMITED IN DURATION TO THE EXPRESS WARRANTIES AND BE OTHERWISE SUBJECT TO AND LIMITED BY THE TERMS OF BURKE'S PRODUCT WARRANTY. SOME STATES DO NOT ALLOW THE EXCLUSION OF CERTAIN IMPLIED WARRANTIES, SO THE ABOVE LIMITATION MAY NOT APPLY TO YOU.

Warranty Exclusions: The above stated warranties do not cover: "cosmetic" defects, such as scratches, dents, marring, or fading; damage due to incorrect installation, vandalism, misuse, accident, wear and tear from normal use, exposure to extreme weather, immersion in salt or chlorine water, unauthorized repair or modification, abnormal use, lack of maintenance, or other cause not within Burke's control; and

Limitation of Remedies: Burke is not liable for consequential or incidental damages, including but not limited to labor costs or lost profits resulting from the use of or inability to use the products or from the products being incorporated in or becoming a component of any other product. If, after a reasonable number of repeated efforts, Burke is unable to repair or replace a defective or nonconforming product, Burke shall have the option to accept return of the product, or part thereof, if such does not substantially impair its value, and return the purchase price as the buyer's entire and exclusive remedy. Without limiting the generality of the foregoing, Burke will not be responsible for labor costs involved in the removal of products or the installation of replacement products. Some states do not allow the exclusion of incidental damages, so the above exclusion may not apply to you.

The environment near a saltwater coast can be extremely corrosive. Some corrosion and/or deterioration is considered "normal wear" in this environment. Product installed within 500 yards of a saltwater shoreline will only be covered for half the period of the standard product warranty, up to a maximum of five years, for defects caused by corrosion. Products installed in direct contact with saltwater or that are subjected to salt spray are not covered by the standard warranty for any defects caused by corrosion.

Contact your local Burke Representative for warranty information regarding Burke Turf® and Burke Tile products.

Terms of Sale

Pricing: Prices published in this catalog are in USD, are approximate and do not include shipping & handling, surfacing, installation nor applicable taxes. All prices are subject to change without notice. Contact your Burke representative for current pricing. Payments are to be made in USD.

Weights: Weights are approximate and may vary with actual orders.

Installation: All equipment is shipped unassembled. For a list of factory-certified installers in your area, please contact your Burke representative.

Specifications: Product specifications in this catalog were correct at the time of publication. However, product improvements are ongoing at Burke, and we reserve the right to change or discontinue specifications without notice.

Loss or Damage In Transit: A signed bill of lading is our receipt from a carrier that our shipment to you was complete and in good condition upon arrival. Before you sign, please check the Bill of Lading carefully when the shipment arrives to make sure nothing is missing and there are no damages. Once the shipment leaves our plant, we are no longer responsible for any damage, loss or shortage.

For more information regarding the warranty, call Customer Service at 920-921-9220 or 1-800-356-2070.

01/2024



Bloomfield Hills Board of Education

Memo

To: Superintendent and Board of Education
From: Board of Education
Date: February 24, 2025
Re: Selection of Candidate for Michigan School Boards Association Board of Directors

Recommended Motion:

I move the Board of Education of Bloomfield Hills Schools to designate (name) as the Region 8 candidate for the MASB Board of Directors, and to direct the Office of the Superintendent to cast the vote accordingly.

Background Information:

The Michigan Association of School Boards (MASB) is holding an election for the MASB Board of Directors. Each district receives one ballot, which must be submitted electronically by the school district. The Board may cast a vote for one candidate in Region 8, for a three-year term, open seat.

The candidate profiles have been attached for information.

ATTACHMENTS:

File Name	Description
📎 2025_bod_elections_booklet.pdf	MASB Board of Directors Candidate Booklet



MASB
MICHIGAN ASSOCIATION
OF SCHOOL BOARDS



**BOARD *of*
DIRECTORS
ELECTIONS**

2025

MASB Bylaws – Article IV – Membership

Section 2. Active Members. The board of education of any public school district in Michigan may become an active member of the Association. Active members of the Association shall be divided into eight regions. The regions shall be designated according to intermediate school district boundaries. The regions shall be as follows:

Region 1. Copper Country ISD, Delta-Schoolcraft ISD, Dickinson-Iron ISD, Eastern Upper Peninsula ISD, Gogebic-Ontonagon ISD, Marquette-Alger RESA and Menominee County ISD.

Region 2. Alpena-Montmorency-Alcona ESD, Charlevoix- Emmet ISD, Cheboygan-Otsego-Presque Isle ESD, COOR ISD, Iosco RESA, Manistee ISD, Northwest Education Services and Wexford-Missaukee ISD.

Region 3. Ionia County ISD, Kent ISD, Mecosta-Osceola ISD, Montcalm Area ISD, Muskegon Area ISD, Newaygo County RESA, Ottawa Area ISD and West Shore ESD.

Region 4. Bay-Arenac ISD, Clare-Gladwin RESD, Clinton County RESA, Gratiot-Isabella RESD, Midland County ESA, Saginaw ISD and Shiawassee RESD.

Region 5. Genesee ISD, Huron ISD, Lapeer County ISD, Sanilac ISD, St. Clair County RESA and Tuscola ISD.

Region 6. Allegan Area ESA, Barry ISD, Berrien RESA, Branch ISD, Calhoun ISD, Heritage Southwest ISD, Kalamazoo RESA, St. Joseph County ISD and Van Buren ISD.

Region 7. Eaton RESA, Hillsdale County ISD, Ingham ISD, Jackson County ISD, Lenawee ISD, Livingston ESA, Monroe County ISD and Washtenaw ISD.

Region 8. Macomb ISD, Oakland Schools and Wayne RESA.

Active members shall also be divided into the following seven groups based on pupil membership.

Group I All intermediate districts;

Group II School districts with a pupil membership of 0 - 1,400;

Group III School districts with a pupil membership of 1,401 - 2,500;

Group IV School districts with a pupil membership of 2,501 - 5,000;

Group V School districts with a pupil membership of 5,001 - 11,000;

Group VI School districts with a pupil membership of 11,001 - 40,000; and

Group VII School districts with a pupil membership more than 40,000.

Table of Contents

Board of Directors’ Elections—Candidate Information and Email Voting Procedures 4

Region 6 (One-Year Term)

TiAnna Harrison	Kalamazoo Public Schools, Kalamazoo County	5
Elizabeth O’Dell	St. Joseph County ISD, St. Joseph County	6

Region 7 (Three-Year Term)

Guillermo Z. Lopez	Lansing School District, Ingham County	7
Cory McLaughlin	Jefferson Schools, Monroe County	8
Jack Temsey	Eaton RESA, Eaton County	9

Region 8 (Three-Year Term)

Jason Babbage	Allen Park Public Schools, Wayne County	10
Dr. Anisha Hannah	Pontiac School District, Oakland County	11
Paul Kolin	Bloomfield Hills Schools, Oakland County	12
Roderick Means	Westwood Community School District, Wayne County	13
Randel Meisner	Fitzgerald Public Schools, Macomb County	14
Scott Wallace	Fraser Public Schools	15
Ursula (Wester) Rogers	Romulus Community Schools, Wayne County	16
Lisa Valerio-Nowc	Clintondale Community Schools, Macomb County	17

Note: Incumbents are **bolded**

Board of Directors' Elections—Candidate Information and Email Voting Procedures

This year, eight seats on the MASB Board of Directors are up for election.

The MASB Board of Directors is comprised of 23 members, including three at-large directors. Sixteen directors shall be elected from the eight regions, with two elected from each region; and one director per group shall be elected from Groups V, VI and VII. Directors are elected by active member school boards and, each year, several seats are up for election. The MASB President will nominate a member to serve as an at-large director, subject to Board approval.

Board Limitations:

Article VIII, Section 6 of the MASB Bylaws permits only one director to be elected or appointed from any one local or intermediate school district board.

According to MASB Bylaws Article VIII, Section 8, if any nomination for the Board of Directors is unopposed, the Board of Directors shall declare the unopposed candidate elected without conducting an election for the uncontested group or region.

This year, the following seats on the MASB Board are up for election (one seat each, three-year terms unless otherwise noted): Regions 1 (two-year term), 3, 4, 6 (open seat; one-year term), 7, 8 (open seat) and Groups V and VI. If you're unsure of your district's region or group, please see the list on page 2.

- **Region 1 will continue to be represented by Kristen Cambensy, Marquette Area Public Schools, (unopposed, no ballots will be sent)**
- **Region 3 will continue to be represented by Rick Dernberger, Zeeland Public Schools and Ottawa Area Intermediate School District, (unopposed, no ballots will be sent)**
- **Region 4 will continue to be represented by John Tramontana, DeWitt Public Schools, (unopposed, no ballots will be sent)**
- **Group V will continue to be represented by Stephen Hyer, Clarkston Community Schools, (unopposed, no ballots will be sent)**
- **Group VI will continue to be represented by Marc Siegler, Walled Lake Consolidated Schools, (unopposed, no ballots will be sent)**

Voting in Regions 6, 7 and 8 will take place via an online ballot. No local district/ISD funds can be used to campaign for anyone running for a seat. To help your board make an informed decision, the following pages contain background information and statements from each of the candidates.

Each district received ONE ballot, which was emailed to the superintendent secretary on record with MASB on Friday, Jan. 24, 2025. These ballots **CANNOT** be forwarded to anyone else. Once your board makes a decision on which candidate it wishes to vote for, please convey this information to your superintendent secretary.

Completed ballots must be cast and confirmed by the superintendent secretary by **1 p.m. on Wednesday, March 5, 2025.**

Unofficial election results will be available on the voicemail recording at 517.327.5915 as soon as possible, but generally after 2 p.m. on the deadline date. They will also be sent out via email that afternoon. Official results will be approved at the March 14, 2025, Board of Directors' meeting, which newly elected directors should plan to attend.

To summarize:

- Ballot deadline is **1 p.m. on Wednesday, March 5, 2025.**
- MASB would like to remind all candidates for the MASB Board of Directors that no school district funds can be used for campaigning during the election. This rule prohibits a candidate from using their school district email account to send messages to other school board members. Therefore, a personal email account must be used for campaigning purposes when running for the MASB Board of Directors. If you have any questions about what may or may not constitute an expenditure of school district funds, please contact MASB's Legal Counsel Brad Banasik, J.D. at bbanasik@masb.org or **517.327.5929.**
- An electronic file containing the physical addresses and email addresses for the voting group or region shall be made available to each candidate running for election to the board of directors. The revokable license to use the addresses shall be limited to contacting school board members to share information about the MASB Board of Directors' election.
- Have questions? Contact Cheryl Huffman at **517.327.5915** or chuffman@masb.org.

Region 6 (One-Year Term)



TiAnna Harrison

Kalamazoo Public Schools, Kalamazoo County

Time served on this board:

10 years

Offices held:

President, Vice President, Secretary and Treasurer

MASB Certification:

Certified Boardmember Award
Award of Merit
Award of Distinction
Master Boardmember
Master Diamond

Election Statement:

My name is TiAnna Harrison, and as the current Board President for Kalamazoo Public Schools Board of Education, I bring over a decade of governance and leadership experience. Appointed in 2014, and reelected in 2020, I have had the honor of serving my community in various capacities, including Vice President, Secretary and Treasurer.

Through these positions, I have had a firsthand view of the challenges and opportunities in education, especially as we work to ensure all students have equitable access to high-quality learning experiences.

My experience serving in a district with diverse needs has given me a comprehensive understanding of the complexities facing school boards across Michigan, and I believe I can bring valuable insights to MASB. I am passionate about the power of public education to transform lives. Our work as school board members is critical in ensuring that every child has access to a high-quality education, no matter where they live.

From advocating for equitable funding to addressing the mental health needs of students, the role of school boards has never been more important. Through my years of service, I have seen firsthand how strategic decision-making, thoughtful governance, and strong community partnerships can improve outcomes for students. I am seeking a seat on the MASB Board of Directors because I believe that the challenges we face in Michigan's education system require a unified and strategic approach.

I am particularly focused on the importance of state-level policies that allow local school boards to address the unique needs of their districts. I want to ensure that Michigan school boards have the tools and support they need to make informed decisions that benefit all students.

From ensuring equitable funding to supporting the mental and emotional well-being of students and staff, I am eager to contribute my experience and insights to support school boards across the state and advocate for policies that will create better outcomes for Michigan's children.

I would be honored to not only serve on the MASB Board of Directors, but also to continue advocating for policies that prioritize the needs of students, support educators, and strengthen our communities. Together, we can ensure that every Michigan student has the opportunity to succeed.

Thank you for your consideration.

Sincerely,

TiAnna L. Harrison

Kalamazoo Public Schools

Trustee – Board of Education



Region 6 (One-Year Term)

Elizabeth O'Dell

St. Joseph County ISD, St. Joseph County

Time served on this board:

27 years

Offices held:

President, Vice President, Secretary and Treasurer

MASB Certification:

- Certified Boardmember Award
- Award of Merit
- Award of Distinction
- Master Boardmember
- Master Diamond

Election Statement:

The MASB is our collective voice on education at the state level, and it allows board members to be informed about educational issues. I think the Director for the Region's role is to ensure that our voice is heard as the MASB discusses issues and concerns. The Past President, Kathleen Moore, was able to model how to accomplish that task positively. I cannot fill her shoes; I am unsure if anyone can.

I have been an active St. Joseph County ISD member for 27 years. I have taken advantage of opportunities to learn about best practices for serving and supporting the education process in our communities. I have held various positions, from member to president.

I have worked with the parent-teacher association, band, and athletic booster clubs. I have served on the special education advisory committee. I have enjoyed serving as a delegate to MASB membership meetings in my county. Through this process, I have learned what various boards are concerned about as they present resolutions and amendments to the Board of Directors, which has deepened my understanding of how our collective needs are connected.

I have and will continue to advocate for a strong public education. My children and I are products of public education. I obtained my bachelor's degree from Ball State University and my graduate degree from Western Michigan University.

I am not new to service, advocacy, listening, and striving to assist others to make positive change. I am a retired CEO of St. Joseph County Community Mental Health and use my time currently as a volunteer in my church, for American Red Cross Disaster Relief, as a substitute teacher, as well as working with a variety of social action services through my sorority, Delta Sigma Theta Sorority, Incorporated.

I am seeking this position to advocate for the needs of our small and large communities. I am a champion for public education, and with your vote, I can take my commitment to this service to the next level.

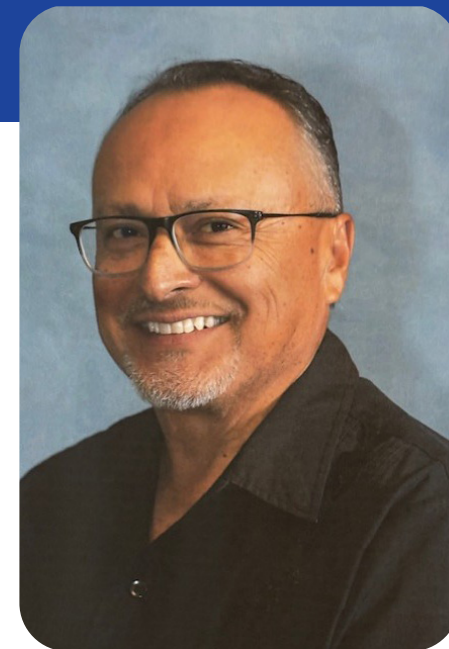

Region 7 (Three-Year Term)

Guillermo Z Lopez INCUMBENT

Lansing School District, Ingham County

Time served on this board:

24 years

Offices held:

President, and Treasurer

MASB Certification:

- Certified Boardmember Award
- Award of Merit
- Award of Distinction
- Master Boardmember

Election Statement:

As we welcome the new year, we are also aware that changes in education funding from the federal government are very possible. As your director from Region 7, I will work closely with our MASB staff and pay close attention to how these changes may affect our educational system here in Michigan. I will also continue to support the work MASB has done in the area of equity in education in all its forms. Additionally, I will continue supporting districts that need training but are not in a position to cover the costs. I very much appreciate MASB staff who are continually looking at ways that we can expand these funding efforts. Finally, I hope you have enjoyed the newsletter coming directly from Region 7.

Region 7 (Three-Year Term)



Cory McLaughlin

Jefferson Schools, Monroe County

Time served on this board:

11 years

Offices held:

President and Secretary

MASB Certification:

Certified Boardmember (CBA 101)

Election Statement:

Since joining the Jefferson School Board in 2014, I have been dedicated to ensuring that every decision we make is in the best interest of our students. I am passionate about creating opportunities for all learners and believe that every child deserves access to a high-quality education that meets their unique needs and aspirations.

Career and Technical Education (CTE) programs are a priority for me because they provide students with real-world skills and open doors to meaningful careers. I also strongly advocate for advanced classes to challenge and inspire high-achieving students, ensuring they are prepared for post-secondary education and beyond. Equally important is my commitment to special education, as I believe every child, regardless of ability, deserves the resources and support to thrive.

My experience on the Jefferson School Board has taught me the importance of collaboration, fiscal responsibility and community engagement. I bring a student-centered approach to decision-making and strive to build partnerships that benefit our schools. Serving on the MASB Board of Directors would allow me to expand this work, sharing best practices and advocating for policies that empower all districts to succeed.

I am running for this position because I am deeply committed to advancing education in Michigan and ensuring that every child has access to the tools and opportunities they need to achieve their full potential.

Region 7 (Three-Year Term)



Jack Temsey

Eaton RESA, Eaton County

Time served on another board:

8 years

Potterville Public Schools

Offices held:

Secretary and Treasurer

Time served on this board:

8 years

Offices held:

President, Vice President, Secretary and Treasurer

MASB Certification:

Certified Boardmember Award

Award of Merit

Award of Distinction

Master Boardmember

Master Diamond

Master Platinum

Election Statement:

As a Board of Education Trustee, I feel we are the voice for our children. We need to utilize this voice to ensure we can offer our children the education they deserve, regardless of the struggles that we face behind the scenes.

We need to direct this voice to those who create legislation that we feel will adversely affect public education, as well as remember to offer praise to those who show us favor and offer to help. I believe the voice of our boards and communities can make a difference. I have strived to become the best board member I can be. One of the ways that I have tried to accomplish this is by becoming certified through the MASB's CBA program. I have gained a wealth of knowledge by attending classes, conferences and other various events as well as networking with board members from around the state.

Public education is as diverse as our country. There are no single fix-all solutions that work for every school district. I feel that bringing the voice of small communities and small districts to the forefront is important. I would like to continue advocating to provide

adequate and equitable funding for ALL districts. Adequate funding is sufficient funding to provide basic schooling. Equitable funding is based on fairness.

I previously served the Potterville Public Schools Board of Education for eight years. During this time, I served on the Policy, Community Relations and Technology Committees, as well as Secretary and Treasurer. I have been an Eaton RESA Trustee for eight years, serving on the Building and Grounds and Finance and Audit Committees as well as Secretary, Vice President and Treasurer. I am currently serving again as President.

Additionally, I have served MASB as a member of the Curriculum and Instruction Committee and Government Relations Committee plus served as its Vice Chairman, also on the Resolutions and Bylaws committee, and as its Vice Chairman. I am currently serving again on the Government Relations Committee as its Vice Chairman.

I would be honored to serve on the MASB Board of Directors to represent you, our Region, and our students. I want to bring your voices to the table to further benefit the future of public education.



Region 8 (Three-Year Term)

Jason Babbage

Allen Park Public Schools, Wayne County

Time served
on this board:

2 years

MASB Certification:

Certified Boardmember Award
Award of Merit

Election Statement:

I am an alumnus and lifelong resident of the Allen Park Public School District. Family and education are at the top of my interests, loves and passions, and certainly go hand in hand with the MASB Board of Directors position for Region 8. Inspired by family members holding political positions leading the way and showing me what it is to serve the community; I can only hope to follow in their footsteps and use my unique position and family connections to influence policy.

I am looking forward to serving on the MASB Board of Directors to help promote a unified and communitive board of directors that focuses on the major issues facing us in the educational community. Some of these issues include unfunded policies, declining enrollment, higher education standards, advances in educational technology, and more. To navigate these issues, we need to be open to change and willing to support new ideas whether it is adding sensory rooms or going from textbooks to technology.

I hold a master's degree in automotive systems engineering and a bachelor's degree in mechanical engineering from U-M Dearborn, and work at Ford Motor Company as an engineer in exterior automotive lighting and am considered one of the top experts in headlamp aim (HLA). I achieved my MASB Level 2 award of merit and look forward to getting more MASB classes under my belt. I have two children attending Allen Park schools and it's family that's been the driving force of involvement in the community and schools.

I would like to serve on the MASB Board of Directors because I believe I will bring a different perspective, drive and policy influence that will be beneficial to Region 8.



Region 8 (Three-Year Term)

Dr. Anisha Hannah

Pontiac School District, Oakland County

Time served
on this board:

3 years

Offices held:

President and
Secretary

MASB Certification:

Certified Boardmember
Award of Merit
Award of Distinction

Election Statement:

I view education as the key to unlocking the door of possibilities. I believe that every child should have access to a quality education. One that will equip them with the skills and knowledge to lead productive, fruitful lives and make a positive contribution to society. I believe that every student can learn; some may require the use of different methodologies. My concern about the educational system is that too much emphasis has been placed on test scores as opposed to the success of the whole child.

Currently, as the Director of Strategic Partnership & Initiatives with the Pontiac Collective Impact Partnership, I lead collaborative efforts with nonprofits, government agencies, and educational institutions to enhance economic and academic outcomes. In this role, I have successfully developed initiatives and set goals for the City of Pontiac with partners that support Oakland County's goal of 80 by 30, ensuring program sustainability and growth. My experience as Board President with the City of Pontiac School Board of Education has further honed my ability to manage complex budgets, engage with diverse stakeholders, and advocate for initiatives that benefit community members from various socioeconomic backgrounds. These experiences have equipped me with the skills to identify challenges, implement data-driven improvements, and ensure that programs achieve measurable outcomes.

It is my desire to serve on the MASB Board of Directors to provide a voice for the minority students that reside in lower socioeconomic backgrounds. The views and opinions of minority students and families are often overlooked and unheard. Serving on the MASB Board of Directors would allow me the opportunity to represent a demographic and community who benefits the most from public education.

I am enthusiastic about the opportunity to learn and contribute to impactful programs and policies that will support children in Michigan's school districts.

I am eager to bring my dedication to education and the Pontiac community to the MASB platform.

Region 8 (Three-Year Term)



Paul Kolin

Bloomfield Hills Schools, Oakland County

Time served
on this board:

10 years

Offices held:

President, Vice
President, Secretary
and Treasurer

MASB Certification:

Certified Boardmember Award

Award of Merit

Award of Distinction

Election Statement:

Education is the cornerstone of our society, shaping not only the minds of the next generation but also the future of our communities and the world. I believe that a high-quality education system equips students with the skills and knowledge necessary to thrive, fosters critical thinking, and nurtures a lifelong love of learning. Beyond academics, education must prepare individuals to engage as informed, empathetic and responsible citizens.

My passion for education stems from witnessing its transformative power in my own life and in the lives of others. I firmly believe that every child deserves access to equitable opportunities, regardless of their background or circumstances. This requires a commitment to removing barriers, supporting educators, and fostering innovative practices that address the diverse needs of all learners.

Serving on the MASB board is an opportunity to advocate for these values at a broader level. The Michigan Association of School Boards plays a pivotal role in strengthening public education by providing leadership, governance and support to local districts. As a board member, I would work collaboratively to ensure that policies and resources are aligned with the goal of fostering student success and community engagement.

My background in Bloomfield Hills for the last 10 years and being a teacher in the past has equipped me with the skills to navigate complex challenges, analyze data-driven solutions, and build consensus among diverse stakeholders. I am committed to listening to educators, parents, and students to understand their needs and bring their voices to the decision-making table.

By serving on the MASB board, I hope to contribute to a shared vision of educational excellence, ensuring that every child in Michigan receives the education they deserve. Together, we can create a stronger future for our students and our communities.

Region 8 (Three-Year Term)



Roderick Means

Westwood Community School District, Wayne County

Time served
on this board:

28 years

Offices held:

President, Vice
President, Secretary
and Treasurer

MASB Certification:

Certified Boardmember Award

Award of Merit

Award of Distinction

Master Boardmember

Master Diamond

Master Platinum

President's Award

Election Statement:

As a passionate advocate for quality education, my vision for our educational system centers on equity, innovation and community engagement. Every student, regardless of background, should have access to high-quality educational opportunities that prepare them for future success. My primary concerns include addressing disparities in educational resources, integrating technology, and fostering strong partnerships within our communities.

As a single parent of two young boys, I began as a little league baseball and football coach. I served a Cub and Boy Scout leader, from Tiger Cub Coordinator to Cubmaster and Assistance Boy Scout leader. I served on many Athletic and booster clubs in the High School. I spearheaded initiatives that improved academic outcomes and strengthened community ties. For the last 20 years, I have worked as an Application Developer at the University of Michigan Ann Arbor, gaining valuable insights into educational technology.

I have actively contributed to the field of education beyond my immediate roles by serving on various MASB committees, including Government Relations, Bylaws and Policy, and Board Leadership and Training. These committees have allowed me to work collaboratively on critical issues affecting our schools and have deepened my understanding of governance and policy frameworks. Additionally, I have served as an MASB Board Mentor, supporting new board members in their roles and fostering effective leadership and governance.

My decision to seek a position on the MASB Board of Directors stems from a deep commitment to effecting systemic change. Serving on the board will allow me to leverage my experience to advocate for equitable funding, support professional development for educators, and integrate technology to enhance learning. I am dedicated to fostering transparency and accountability to ensure that all decisions are in the best interest of our students. In conclusion, my extensive experience in education, coupled with my dedication to improving our educational system, uniquely positions me to contribute meaningfully to the MASB Board of Directors. I am eager to drive positive change, support our educators, and ensure every student has the opportunity to succeed. Thank you for considering my candidacy.

Region 8 (Three-Year Term)



Randel Meisner

Fitzgerald Public Schools, Macomb County

Time served
on this board:

12 years

Offices held:

Vice President,
Secretary and
Treasurer

MASB Certification:

- Certified Boardmember Award
- Award of Merit
- Award of Distinction
- Master Boardmember
- Master Diamond
- Master Platinum
- President's Award

Election Statement:

CONCERNS: We need sustainable funding for public education at all levels. Teacher retention. Teacher shortages. Full funding for special education. Offset the MPSERS cost.

EXPERIENCE: MISD Legislative Committee, MISD Budget Review, participate in annual legislative strategic planning sessions. Attend the state Annual Leadership Conferences and National School Board Conferences. Awarded the MASB President's Award.

I would appreciate a chance to serve on the MASB board of directors so that I can add a fresh viewpoint to the board. I enjoy working with other board members for a common goal.

Region 8 (Three-Year Term)



Scott Wallace

Fraser Public Schools

Time served
on this board:

8 years

Offices held:

President, Vice
President and
Treasurer

MASB Certification:

- Certified Boardmember Award
- Award of Merit
- Award of Distinction
- Master Boardmember

Election Statement:

Region 8 is comprised of many different students with many different backgrounds, and all deserve a quality education regardless of where they live.

I am proud to serve in the same district where I, and my three children, have graduated from. I am an Eagle Scout and have coached soccer and basketball as well as served as an officer on the Board of Directors for the Fraser Soccer Club for four years. I have been the President of Fraser Public Schools Board of Education since 2022 and a board member since 2017.

I have worked with the MASB since becoming a school board member and have seen the many good things that come from us all working towards making education in Michigan better for all of our kids.

Working on the MASB legislative committee for three years I got to see up close how important it is for us to continue to be heard in Lansing and I hope to take this opportunity to continue making sure our region's concerns are heard. I thank you for the opportunity to serve.



Region 8 (Three-Year Term)

Ursula (Wester) Rogers

Romulus Community Schools, Wayne County

Time served
on this board:

8 years

Offices held:

President, Secretary
and Treasurer

MASB Certification:

Certified Boardmember Award
Award of Merit
Award of Distinction
Master Boardmember

Election Statement:

I am deeply passionate about ensuring that every student in Michigan has access to a high-quality, equitable education. However, there are significant challenges that must be addressed, including disparities in funding, access to resources, and the growing mental health needs of students. These issues disproportionately impact students from marginalized communities, and I firmly believe it is our collective responsibility to create a system that is inclusive, supportive, and designed to meet the needs of all learners.

Throughout my career, I have had the privilege of working in various educational settings, including as a substitute teacher, secretary, human resources professional, and school board member. These roles have provided me with a firsthand understanding of the challenges educators face, from budget cuts to the increasing demands on teachers' time and resources. Additionally, I have served on committees focused on policy, human resources, school improvement, and curriculum, gaining valuable insights into the intricacies of school governance.

Beyond my professional experience, I have been actively involved with the Romulus Athletic Club for 24 years as treasurer and cheerleading coach for a youth football organization. This work has allowed me to connect with students in alternative ways, providing them with positive outlets to compete, grow, and discover what drives them. Through all of these experiences, I have gained a comprehensive understanding of how local school boards can influence state and national education policies. These experiences have strengthened my expertise in governance and advocacy, which I believe would be an asset to the MASB Board of Directors.

I wish to serve on the MASB Board of Directors because I am committed to ensuring that Michigan's school boards have the tools, resources, and support they need to advocate effectively for students. MASB is uniquely positioned to unite school boards across the state to address shared challenges, promote best practices, and advocate for policies that improve funding, access to resources, and student outcomes. I am eager to collaborate with fellow board members to create lasting, positive change for Michigan's students and educators.

Thank you for considering my candidacy.

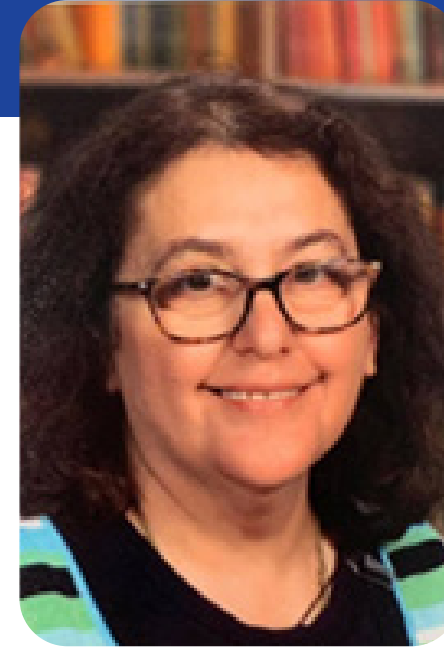

Region 8 (Three-Year Term)

Lisa Valerio-Nowc

Clintondale Community Schools, Macomb County

Time served
on this board:

2 years

Offices held:

Secretary

MASB Certification:

Certified Boardmember Award
Award of Merit

Election Statement:

As a librarian for over thirty years with experiences in school libraries, and in the classroom, I understand the complex issues in education today. Teachers and students are finding their classrooms changing almost daily with new technology, apps and tools that, at times, seem overwhelming. Added to this are the challenges that are faced every day of surviving in a society that seems to be controlled by "notifications" on our phones and computers. My aim is to make my school district a safe place to learn and grow. With this in mind, as a MASB Board member, I believe that my contributions will aid the organization in finding meaningful solutions that will help schools support their communities better.

Education is not just a word that conveys what a person learns. It is what that person does with the education that makes an impact on our community and world. It is an honor to be a part of a profession that guides the next generation. I have been a School Librarian, Library Director of Baker College, and served in leadership positions in public libraries. Currently, I am the Assistant Manager/Children's Librarian at Chaney Branch/Detroit Public Library. In each of these positions I have made it a goal to help children and adults with their lifelong pursuit of learning. In my opinion, once you stop learning, you stop growing.

In closing, it is without a doubt in my mind that I am qualified and ready to serve as a Board of Director member for the MASB. I am ready to serve and make a positive impact with the organization.



MISSION

To provide high-quality educational leadership services for all Michigan boards of education and to advocate for an equitable and exceptional public education that leads to improved outcomes for all students.

VISION

A well-governed, effective public school for every Michigan student.

INFO@MASB.ORG | MASB.ORG | 517.327.5900

1001 Centennial Way, Suite 400 • Lansing, Michigan 48917-8249